

A digital spectrometer approach to obtaining multiple time-resolved gamma-ray spectra for pulsed spectroscopy

H. Tan ^{a,*}, S. Mitra ^b, A. Fallu-Labruyere ^a, W. Hennig ^a, Y.X. Chu ^{a,1},
L. Wielopolski ^b, W.K. Warburton ^a

^a XIA LLC, 31057 Genstar Road, Hayward, CA 94544, USA

^b Department of Environmental Sciences, Earth Systems Science Division, Brookhaven National Laboratory, Upton, NY 11973, USA

Available online 12 April 2007

Abstract

Neutron-induced gamma-ray emission and its detection using a pulsed neutron generator system is an established analytical technique for quantitative multi-element analysis. Traditional gamma-ray spectrometers used for this type of analysis are normally operated either in coincidence mode – for counting prompt gamma-rays following inelastic neutron scattering (INS) events when the neutron generator is ON, or in anti-coincidence mode – for counting prompt gamma-rays from thermal neutron capture (TNC) processes when the neutron generator is OFF. We have developed a digital gamma-ray spectrometer for concurrently measuring both the INS and TNC gamma-rays using a 14 MeV pulsed neutron generator. The spectrometer separates the gamma-ray counts into two independent spectra together with two separate sets of counting statistics based on the external gate level. Because the TNC gamma-ray yields are time dependent, additional accuracy in analyzing the data can be obtained by acquiring multiple time-resolved gamma-ray spectra at finer time intervals than simply ON or OFF. For that purpose we are developing a multi-gating system that will allow gamma-ray spectra to be acquired concurrently in real time with up to 16 time slots. The conceptual system design is presented, especially focusing on considerations for tracking counting statistics in multiple time slots and on the placement of pulse heights into multiple spectra in real time.

© 2007 Elsevier B.V. All rights reserved.

PACS: 07.50.Qx; 07.85.Nc; 82.80.Jp; 84.30.Sk

Keywords: Pulsed neutrons; Non-intrusive and non-destructive analysis; Digital signal processing; Digital gamma spectroscopy

1. Introduction

Neutron-induced nuclear reactions using a pulsed neutron generator have been widely used for quantitative multi-element analysis [1,2]. Among the three major types of nuclear reactions, the first is prompt gamma-ray emissions from a target nucleus following inelastic neutron scattering (INS). The second is prompt gamma-ray emissions following thermal neutron capture (TNC) by the target

nucleus after fast neutrons thermalize in the matrix and get absorbed. The third type of reaction occurs whenever following prompt emissions the resulting nucleus is unstable (radioactive) and it decays to the ground level of a stable nuclide according to the radioisotope half-life. This process is conventionally referred to as the delayed activation. The conventional nomenclature for these processes is: (1) INS gamma-ray spectroscopy, these are prompt gamma-rays, (2) TNC gamma ray- or prompt gamma ray-spectroscopy and (3) delayed gamma ray spectroscopy. The thermalization process of the fast neutrons depends on the matrix composition and may take between a few to hundreds of microseconds.

Pulsed neutron generators exploit the fact that gamma-rays from these three types of reactions have different

* Corresponding author. Tel.: +1 510 401 5760x24; fax: +1 510 401 5761.

E-mail address: htan@xia.com (H. Tan).

¹ Present address: KLA-Tencor Corp., 3 Technology Drive, Milpitas, CA 95035, USA.

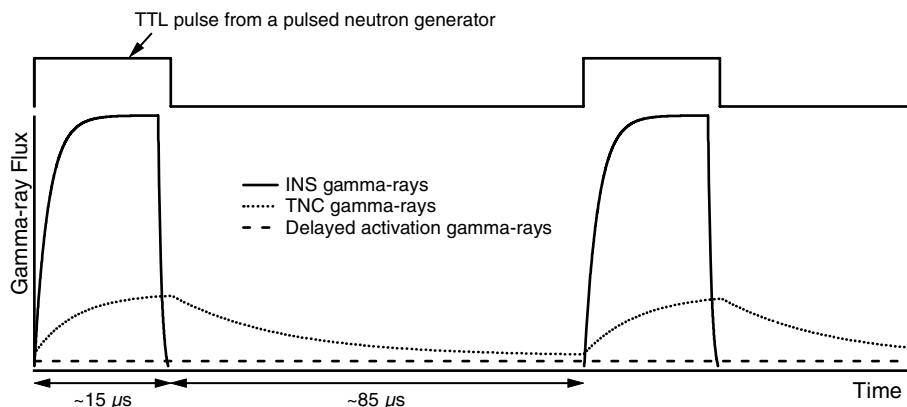

Fig. 1. Temporal characteristics of a pulsed neutron generator.

temporal characteristics. The typical timing scheme of such a neutron generator for a 10 kHz repetition rate is shown in Fig. 1. Fast neutron-induced INS reactions occur during the neutron pulse whereas TNC reactions prevail in between the pulses and depend on the neutron pulsing regimen. Similarly, the delayed activation could occur both during and between the pulses depending on the radioisotope's half-life. By separating the prompt gamma-rays from INS and TNC processes, the signal-to-noise ratio can be improved by reducing the background in either of the spectra and reducing mutually interfering signals. Consequently, this would reduce the minimum detection limit (MDL) which is proportional to the square root of the background. To accomplish this, spectrometer systems are generally operated in either coincidence or anti-coincidence mode, i.e. either counting INS gamma-rays when the neutron generator is ON, or counting TNC prompt gamma-rays when the neutron generator is OFF, respectively [3–5].

We have developed a digital gamma-ray spectrometer [6] for concurrently measuring prompt gamma-rays from both INS and TNC processes using a 14 MeV pulsed neutron generator (model MP320, 250–20 kHz pulse rate, 0–100% duty factor, Thermo Electron Corporation). The Transistor-Transistor Logic (TTL) ON/OFF signal from the neutron generator is connected to the Sync input of an XIA POLARIS digital gamma-ray spectrometer [7], which directs the spectrometer to separate the gamma-ray counts into two independent spectra based on the level of the neutron generator's TTL signal. Because both types of spectra are acquired in a single counting period by this means, together with two separate sets of input count rate, output count rate, live time and real times, data acquisition times are reduced substantially in addition to improving signal-to-noise ratios. The quantitative data analyses are also improved by having separate counting statistics for the ON and OFF periods since the counting rates during and between the neutron bursts differ substantially.

Further subdividing data acquisition within the ON and OFF periods should allow the quantitative data analysis to be further improved because counting rates vary not only

between the ON and OFF periods, but within them as well. A time-resolved analysis that further subdivides the neutron pulse cycle should therefore produce additional information for separating the gamma-rays produced by different nuclear reactions. For that purpose we are developing a multi-gating system that will allow gamma-ray spectra to be concurrently acquired in real time with up to 16 time slots. These 16 time slots can be fairly arbitrarily allocated between the ON and OFF periods with adjustable widths and time delays. The conceptual system design is presented in this paper, paying consideration to tracking counting statistics in multiple time slots and placing pulse heights into multiple spectra in real time.

2. The polaris digital spectrometer

The XIA Polaris is a high-precision, all digital spectrometer, comprising a single digital signal processing channel, a preamplifier power supply and a detector bias supply (up to ± 5000 V) in a desktop module. The Polaris provides up to 64 K channels spectrum length. Connection to the host computer is by USB or EPP (Extended Parallel Port – IEEE 1284). Fig. 2 shows a simplified block diagram of the Polaris' signal processing chain. The input signal from a detector is digitized by a 14-bit 40 MHz Analog-to-Digital Converter (ADC) after some analog signal conditioning mainly to ensure that the signal is within the ADC voltage range and appropriately bandwidth limited. The digital data stream is then passed to a Field Programmable Gate Array (FPGA) called the signal processing FPGA, shown as the dashed-line box on the left in the figure, where major signal processing functions are implemented in parallel. These include the trigger logic and pileup rejection circuitry for pulse arrival detection and pileup rejection, a First-In-First-Out (FIFO) memory block to store waveforms for pulse shape analysis, and an energy filter to capture three consecutive moving sums from the detected pulse, which are sent to the Digital Signal Processor (DSP) to compute the pulse's energy [8]. The FPGA recognizes the neutron ON and OFF periods through the Sync input and attaches to each detected event a tag which

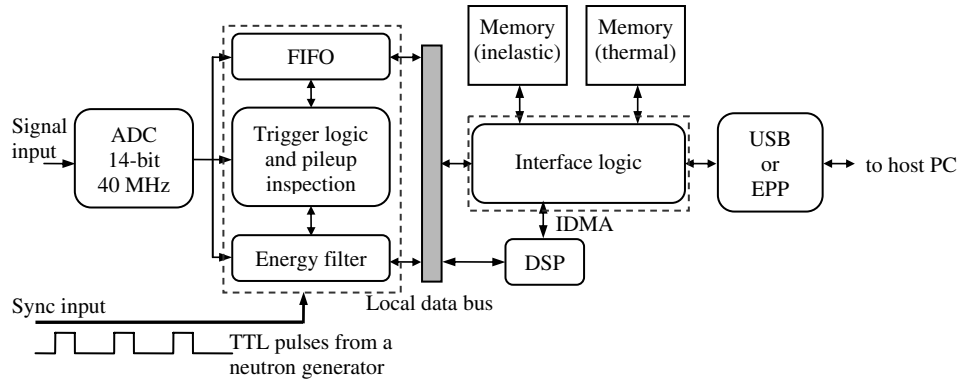

Fig. 2. Simplified block diagram of XIA's Polaris digital spectrometer.

records the level of the TTL neutron ON/OFF signal at the time of detection. The interface logic, another FPGA shown as the dashed-line box on the right that handles memory management and interface communications, utilizes this tag to increment the energy histogram in the corresponding (inelastic or thermal) external memory block after receiving the pulse's energy from the DSP through the local data bus. By this means two independent spectra (up to 32 K channels each) from both inelastic neutron scattering (ON) and thermal neutron capture (OFF) can be concurrently measured. The concurrent measurement of dual spectra using this instrument has been previously reported [6].

3. Conceptual design of a multi-gating system

To create a system that is capable of acquiring multiple time-resolved gamma-ray spectra, the signal processing FPGA and the DSP need to be reprogrammed. Specifically:

- (1) the FPGA needs to track the multiple time slots during the neutron ON or OFF periods in order to tag detected events and record counting statistics within each slot;
- (2) the DSP needs to be modified such that it can accumulate multiple sets of counting statistics; and
- (3) the host interface software also needs modification to be able to set up the multiple time slots.

The time sequence of the proposed system in response to a periodic external gate signal is shown in Fig. 3. Up to 16 time slots can be arbitrarily assigned between two adjacent rising edges of the external gate signal. Each time slot will have its own set of counting statistics, CS_i ($i = 0-15$), namely, live time, number of triggers, number of processed counts and dead time, and a histogram of up to 4 K in length. Prior to starting the data acquisition, two configuration modes can be set by the user. In the first mode, a user can assign arbitrary time slots by specifying the duration of each time slot. Defining the duration of each time slot as Δt_i ($i = 0, 1, \dots, (NumSlots-1)$), then the starting

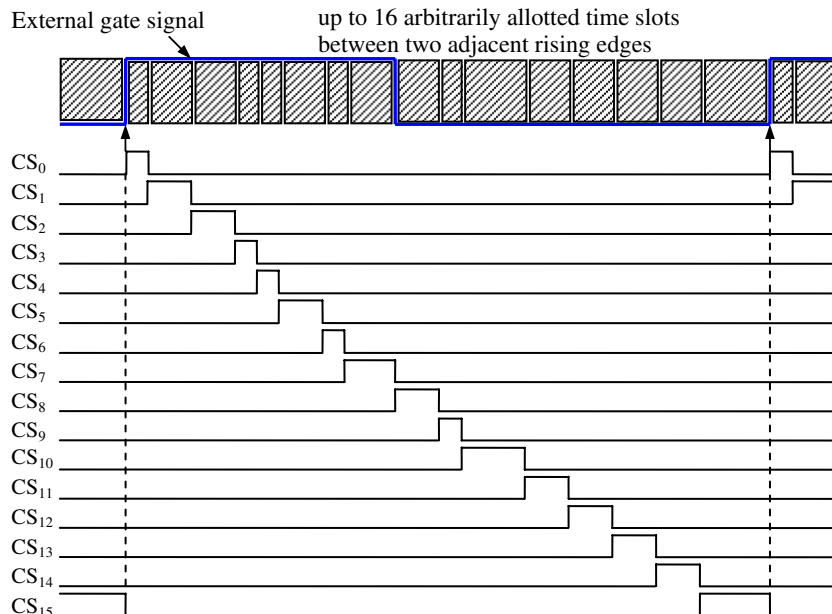

Fig. 3. Time sequence of multi-gating system in response to periodic external gate signal.

time of each slot, t_i , following the rising edge of external gate signal, is:

$$t_i = \sum_{j=0}^{i-1} \Delta t_j \quad (1)$$

In the second mode, a user assigns uniform time slots by specifying the total number of equal-length time slots (up to 16), *NumSlots*. In this case, the starting time of each slot is:

$$t_i = i * \frac{\Delta T}{\text{NumSlots}} \quad (2)$$

where ΔT is the time interval between two adjacent rising edges of the external periodic gate signal. ΔT can be measured by the system itself in a calibration mode in which the time between multiple rising edges is measured and ΔT is derived by averaging the time over the number of edges.

4. Implementation of the multi-gating system

Every time a rising edge of the external gate signal is detected, the first set of counters, CS_0 , is enabled to accumulate triggers or live time. Every event detected in this period will be tagged so that the system knows which spectrum it should put the event into after the event energy is reconstructed in the DSP at a later time. The second set of counters, CS_1 , follows the end of the first period and so on. As soon as the system detects the next rising edge of the external gate signal, it switches the counting back to CS_0 . This both ensures that all the events will be tallied into their correct spectrum and also that any changes of external gate signal frequency and duty cycle will be automatically accommodated.

5. Conclusion

The application of neutron-induced nuclear reactions to multi-element analysis can benefit from the capability of advanced digital gamma-ray spectrometers to acquire multiple time-resolved spectra simultaneously. We presented the conceptual design of a multi-gating system with special considerations for tracking counting statistics in multiple time slots and placement of pulse heights into multiple spectra in real time. No additional hardware is necessary, as the presented method can be implemented in the same instrument that achieved dual “ON/OFF” gating. Experimental data taken with the new design will be reported elsewhere, following experiments at Brookhaven National Laboratory’s test site.

Acknowledgement

This research was sponsored in part by US DOE STTR grant DE-FG02-04ER86200.

References

- [1] C.S. Lim, J. Rad. Nucl. Chem. 262 (2004) 525.
- [2] A.R. Dulloo, F.H. Ruddy, T.V. Congedo, J.G. Seidel, M.E. McIlwain, Appl. Radiat. Isotopes 53 (2000) 499.
- [3] L. Dep, M. Belbot, G. Vourvopoulos, S. Sudar, J. Rad. Nucl. Chem. 234 (1998) 107.
- [4] R. Zeisler, G.P. Lamaze, H.H. Chen-Mayer, J. Rad. Nucl. Chem. 248 (2001) 35.
- [5] R.C. Odom, S.M. Bailey, R.D. Wilson, Appl. Radiat. Isotopes 48 (1997) 1321.
- [6] S. Mitra, L. Wielopolski, H. Tan, A. Fallu-Labruyere, W. Hennig, W.K. Warburton, IEEE Trans. Nucl. Sci. 54 (2007) 192.
- [7] <http://www.xia.com/DGF_Polaris.html>.
- [8] H. Tan, M. Momayezi, A. Fallu-Labruyere, Y.X. Chu, W.K. Warburton, IEEE Trans. Nucl. Sci. 51 (2004) 1541.