

## **OA-30 Current vs. Voltage Feedback Amplifiers**

---

### **ABSTRACT**

One question continuously troubles the analog design engineer: "Which amplifier topology is better for my application, current feedback or voltage feedback?" In most applications, the differences between current feedback (CFB) and voltage feedback (VFB) are not apparent. Today's CFB and VFB amplifiers have comparable performance, but there are certain unique advantages associated with each topology. In general, VFB amplifiers offer:

---

### **Contents**

1	Closed Loop Characteristics .....	2
2	VFB Open Loop Characteristics .....	3
3	Gain Bandwidth Product .....	4
4	CFB Open-Loop Characteristics .....	5
5	Gain Bandwidth Independence .....	6
6	An Internal look at the VFB Topology .....	8
7	An Internal Look at the CFB Topology .....	9
8	Advantages of the CFB Topology .....	10
9	Distortion .....	11
10	Slew Rate .....	12

### **List of Figures**

1	Basic Inverting and Non-Inverting Gain Topologies Hold True for CFB and VFB Amplifiers .....	2
2	VFB Open-loop Characteristics .....	3
3	Open-Loop Gain A(s) and Illustration of the GBP for VFB Amplifiers .....	5
4	CFB Open-Loop Characteristics .....	5
5	Typical VFB Input Stage .....	8
6	Typical CFB Amplifier Input Stage .....	10
7	Basic CFB Topology .....	11

One question continuously troubles the analog design engineer: "Which amplifier topology is better for my application, current feedback or voltage feedback?" In most applications, the differences between current feedback (CFB) and voltage feedback (VFB) are not apparent. Today's CFB and VFB amplifiers have comparable performance, but there are certain unique advantages associated with each topology. In general, VFB amplifiers offer:

- Lower Noise
- Better DC Performance
- Feedback Freedom

Aside from the well-known attribute of CFB amplifiers, gain-bandwidth independence, CFB amplifiers also tend to offer:

- Faster Slew Rates
- Lower Distortion
- Feedback Restrictions

With these common attributes known, the design engineer may still ask: "Why?" This article will examine the basics of the CFB amplifier in comparison with the VFB amplifier. The following aspects of each topology will be examined:

- Closed loop characteristics
- Open loop characteristics
- Input stage differences and advantages

Once these aspects are examined, it will become apparent why VFB amplifiers have better DC specifications and why CFB amplifiers have higher bandwidths for the same power and better linear phase performance over wider bands. Finally, an internal look at the CFB amplifier will explain why distortion and slew rate are enhanced by its topology.

## 1 Closed Loop Characteristics

The basic amplifier design schematics and their equations hold true for both amplifier topologies. *Figure 1* shows the basic circuit topologies and transfer functions for inverting and non-inverting gain configurations. These hold true for both CFB and VFB amplifiers. One point to remember is that the value of the feedback resistor is limited for CFB amplifiers. The CFB amplifier data sheet will provide the recommended  $R_f$  value.

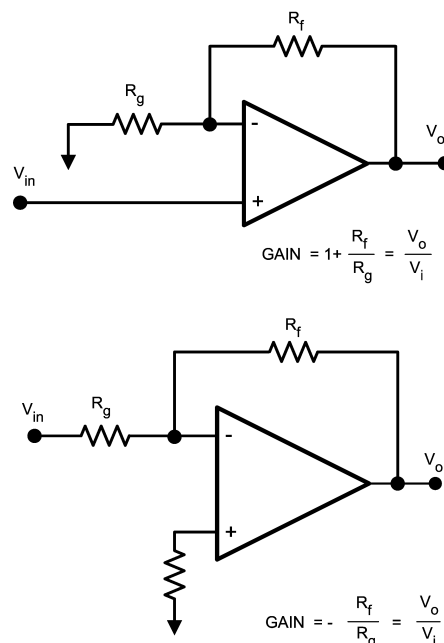

**Figure 1. Basic Inverting and Non-Inverting Gain Topologies Hold True for CFB and VFB Amplifiers**

These transfer functions assume ideal conditions. Under ideal conditions, the open loop gain  $A(s)$  of a VFB amplifier and the open loop transimpedance gain  $Z(s)$  of a CFB amplifier are infinite. Therefore, the ideal transfer function, for the non-inverting topology, is generated as follows:

$$\frac{V_{in}}{R_g} = \frac{V_o - V_{in}}{R_f}$$

$$\frac{V_o}{V_{in}} = \frac{R_f + R_g}{R_g}$$

$$\frac{V_o}{V_{in}} = 1 + \frac{R_f}{R_g}$$

or

$$\text{LET } G = \frac{R_f + R_g}{R_g}$$

$$V_o = V_{in}G$$

The output is equal to the input multiplied by the gain,  $G$ .

## 2 VFB Open Loop Characteristics

The fundamental differences between VFB and CFB amplifiers begin to show when comparing their open-loop characteristics. *Figure 2* illustrates the open-loop characteristics of a VFB amplifier.

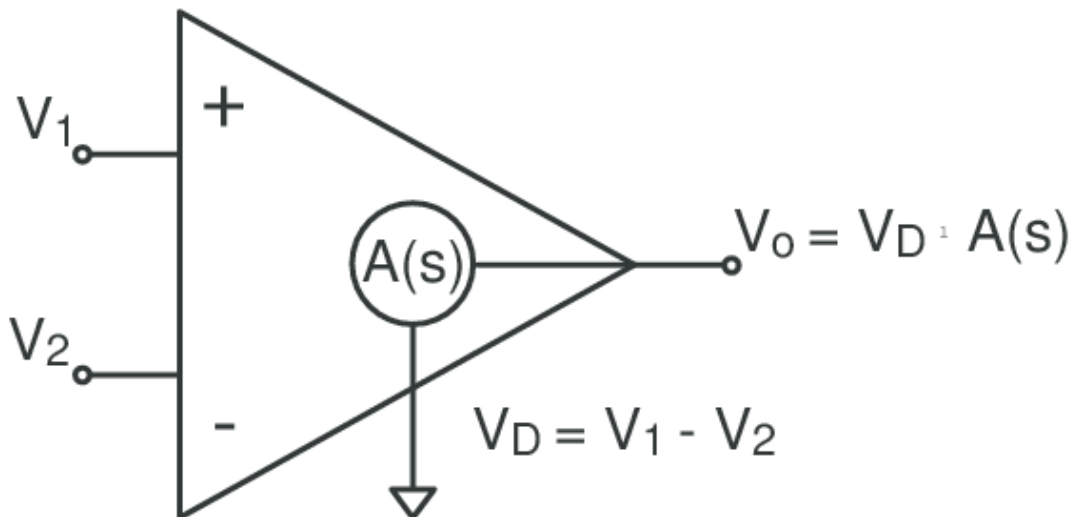

Figure 2. VFB Open-loop Characteristics

The ideal open-loop terminal characteristics are:

- Infinite non-inverting and inverting input impedances
- Zero output impedance

The output is a voltage source that is controlled by the potential difference between the two input terminals of the amplifier, also called the error voltage ( $V_D = V_1 - V_2$ ). The output is equal to this error voltage multiplied by the open loop gain,  $A(s)$ . Once the loop is closed, feedback will attempt to drive the error voltage to zero, hence the term voltage feedback.

### 3 Gain Bandwidth Product

Refer to the non-inverting gain topology of *Figure 1*. Remember that the open loop gain of a non-ideal amplifier is finite. Reevaluating, the non-ideal transfer function for a VFB amplifier becomes:

$$\frac{V_{in} - V_D}{R_g} = \frac{V_o - (V_{in} - V_D)}{R_f}$$

$$V_D = \frac{V_o}{A(s)}$$

$$R_f \left( V_{in} - \frac{V_o}{A(s)} \right) = R_g \left( V_o - V_{in} + \frac{V_o}{A(s)} \right)$$

$$R_f V_{in} - \frac{R_f V_o}{A(s)} = V_o \left( R_g + \frac{R_g + R_f}{A(s)} \right)$$

$$\text{Let } G = \frac{R_f + R_g}{R_g}$$

$$V_o = V_{in} \left( \frac{G}{1 + \frac{G}{A(s)}} \right)$$

As long as  $A \gg G$  then the denominator becomes 1 and the amplifier behaves as it did in the ideal case.

The actual open loop gain is large at DC and rolls off at a rate of 6dB per octave, through most of the frequency range. As the frequency increases, the value of  $A(s)$  decreases. When  $A(s) = G$ , the overall gain of the circuit will be half its DC value. This is commonly referred to as the -3dB bandwidth of the amplifier. The rate at which the bandwidth decreases is proportional to  $1/G$ . For most of the frequency range, the product of gain and bandwidth becomes constant. This is referred to as the gain-bandwidth product (GBP). GBP prevents VFB amplifiers from obtaining high gain and high bandwidths simultaneously. This is illustrated in *Figure 3*.

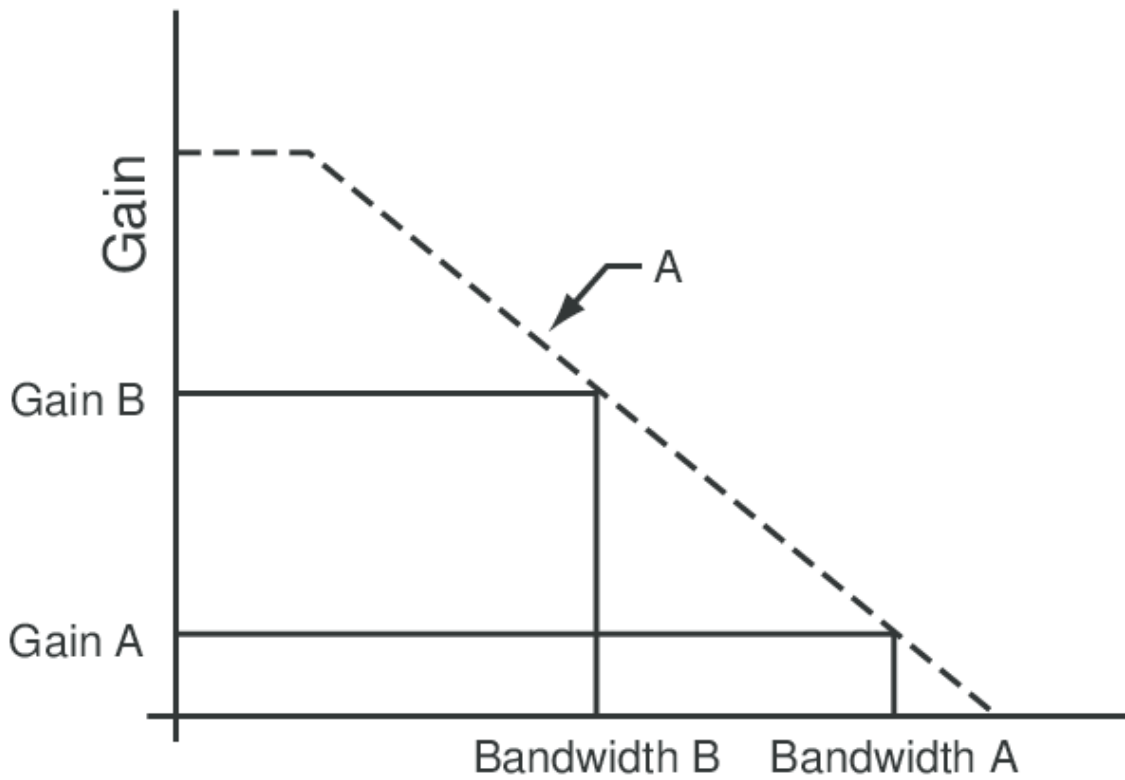

Figure 3. Open-Loop Gain A(s) and Illustration of the GBP for VFB Amplifiers

#### 4 CFB Open-Loop Characteristics

Figure 4 illustrates the open-loop characteristics of a CFB amplifier

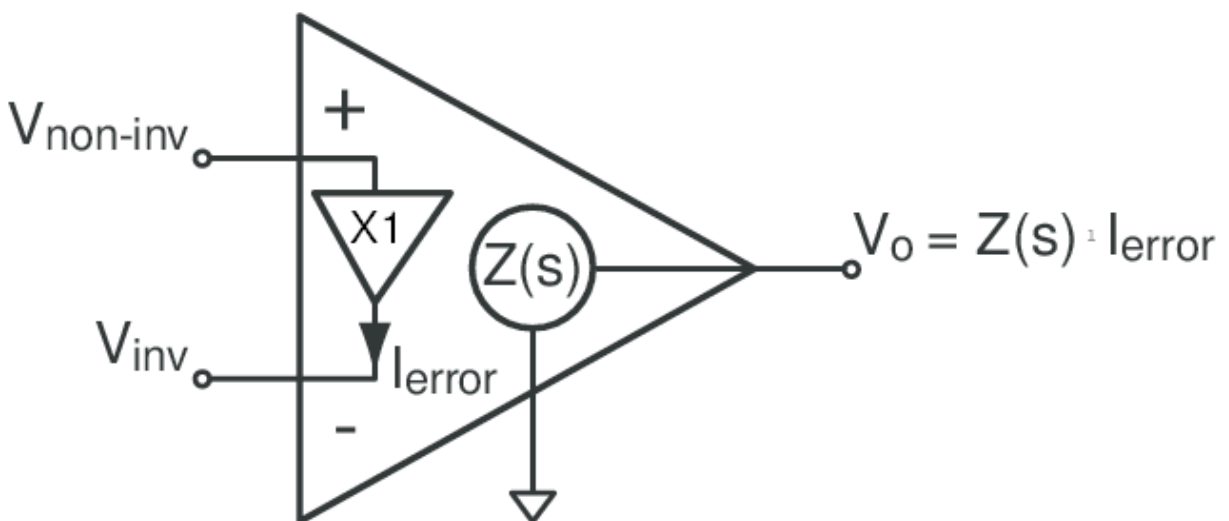

Figure 4. CFB Open-Loop Characteristics

There is a unity-gain buffer between the two inputs of the CFB amplifier. Ideally, this buffer has infinite input impedance and zero output impedance. Therefore, the ideal open-loop terminal characteristics are:

- Infinite non-inverting input impedance
- Zero inverting input impedance
- Zero output impedance

The output is a voltage source controlled by the error current,  $I_{\text{error}}$ , out of the inverting input. Once the loop is closed, feedback will attempt to drive the error current to zero, hence the term current feedback.

## 5 Gain Bandwidth Independence

CFB amplifiers are known for their gain-bandwidth independence. The reason for this attribute is explained by calculating the transfer function of a non-ideal CFB amplifier. The evaluation of the transfer function for non-inverting configuration is shown. The transfer function for an inverting configuration also illustrates the gain-bandwidth independence.

$$I_{\text{error}} = \frac{V_{\text{in}} - V_{\text{o}}}{R_{\text{f}}} + \frac{V_{\text{in}}}{R_{\text{g}}}$$

$$V_{\text{o}} = Z(s) I_{\text{error}}$$

$$\frac{V_{\text{o}}}{Z(s)} = \frac{V_{\text{in}} - V_{\text{o}}}{R_{\text{f}}} + \frac{V_{\text{in}}}{R_{\text{g}}}$$

$$\frac{V_{\text{o}}}{V_{\text{in}}} = \frac{\frac{1}{R_{\text{f}}} + \frac{1}{R_{\text{g}}}}{\frac{1}{Z(s)} + \frac{1}{R_{\text{f}}}}$$

$$\frac{V_{\text{o}}}{V_{\text{in}}} = \frac{R_{\text{g}}}{\frac{Z(s) + R_{\text{f}}}{Z(s)}}$$

$$\text{Let } G = \frac{R_{\text{f}} + R_{\text{g}}}{R_{\text{g}}}$$

$$V_{\text{o}} = V_{\text{in}} \frac{G}{1 + \frac{R_{\text{f}}}{Z(s)}}$$

The CFB transfer function looks very similar to the VFB transfer function. As long as  $Z \gg R_{\text{f}}$ , then the amplifier behaves as in the ideal case. Once  $Z(s)$  drops to where it equals  $R_{\text{f}}$ , then the gain is lowered to 1/2 its DC value. This differs from the VFB case where gain is determined by both  $R_{\text{f}}$  and  $R_{\text{g}}$ . For CFB amplifiers, if the gain is increased by lowering  $R_{\text{g}}$ , rather than increasing  $R_{\text{f}}$ , then the bandwidth is independent of gain.

This expression explains the importance of  $R_f$  for CFB amplifiers. CFB amplifier data sheets provide the recommended  $R_f$  values for various gain settings. An excessively large or small  $R_f$  will compromise stability. Within reason, the feedback resistor can be used to adjust the frequency response. As a rule of thumb, if the value of the recommended  $R_f$  is doubled, then the bandwidth will be cut in half.

## 6 An Internal look at the VFB Topology

By observing the open-loop characteristics of both amplifier topologies, the differences begin to become apparent. However, a closer look at the input stages will shed more insight into the battle, CFB vs. VFB. A typical VFB amplifier input stage is shown in *Figure 5*. It is a common fact that VFB amplifiers tend to have better DC specifications than CFB amplifiers. Most VFB amplifiers have:

- Low input offset voltage ( $V_{io}$ )
- Matched input bias currents ( $I_b$ )
- High power supply rejection ratio (PSRR)
- Good common mode rejection ratio (CMRR)

A close look at the input stages of both topologies will explain why VFB amplifiers tend to have better DC specifications.

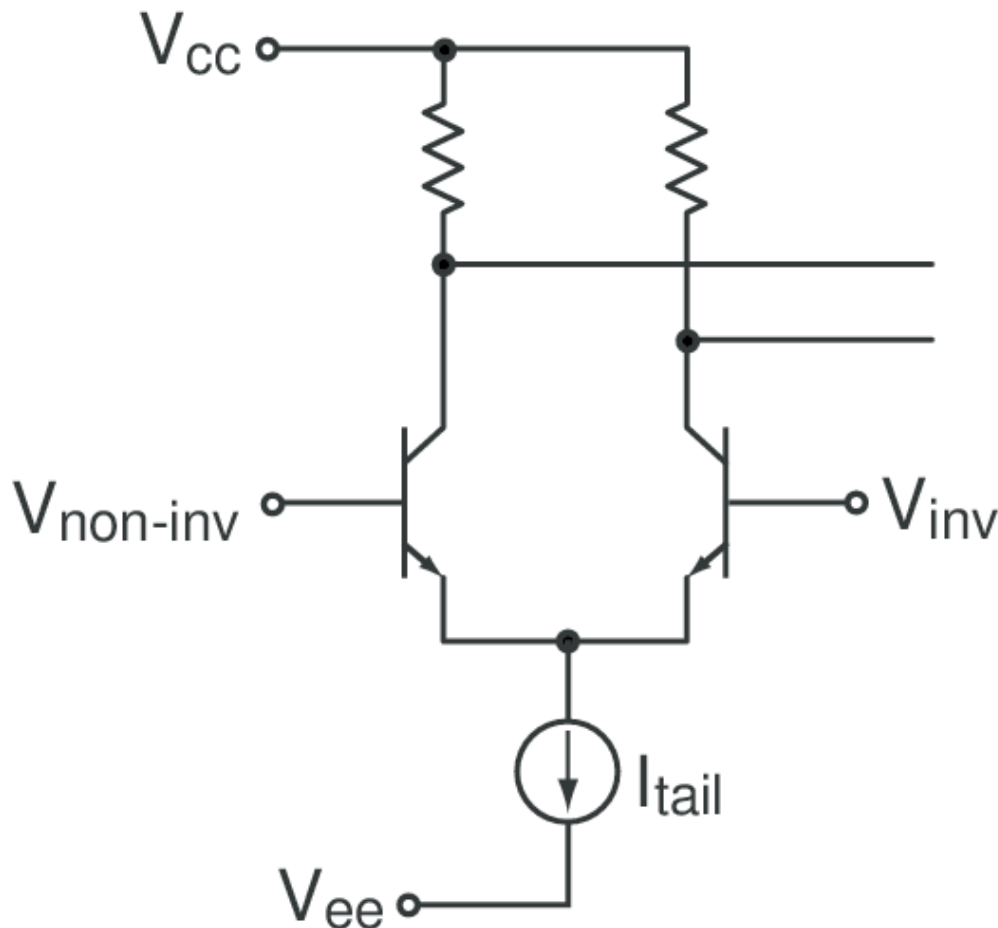

**Figure 5. Typical VFB Input Stage**

The structure of the VFB input stage is the reason for better DC specifications. A VFB input stage is often a simple differential pair, two identical bipolar transistors at the same bias current and voltage. This configuration is often called a balanced circuit because of the symmetry between the two inputs. Because of this symmetry, there will be no input offset voltage unless the devices do not match.



The inputs are the bases of the two transistors. Although the absolute base currents, or input bias currents, may vary considerably due to process variation and temperature, again unless the devices are not identical, the input bias currents will match.

When either the supply voltage or the common mode input voltage is altered, the change in the collector to emitter voltages is matched for both of the input transistors. Changes in the devices bias point could effect offset, but again due to the balanced topology, the bias currents match and offset voltage is little effected. The result of this is good CMRR and PSRR.

## 7 An Internal Look at the CFB Topology

The input stage of a CFB amplifier will also describe a few inherent DC traits of the CFB amplifier:

- Nonzero  $V_{io}$
- Unmatched  $I_b$

The input stage of a typical CFB amplifier is illustrated in *Figure 6*. It is a voltage buffer. For the offset voltage to be zero, the  $V_{ee}$  of the NPN transistors would have to match the  $V_{ee}$  of the PNP. Since these devices are constructed differently, there is no reason why they would inherently match. Bias currents in CFB amplifiers are also fundamentally mismatched. The non-inverting bias current is the difference between two base currents where the inverting bias current depends on the errors produced in the next stage.

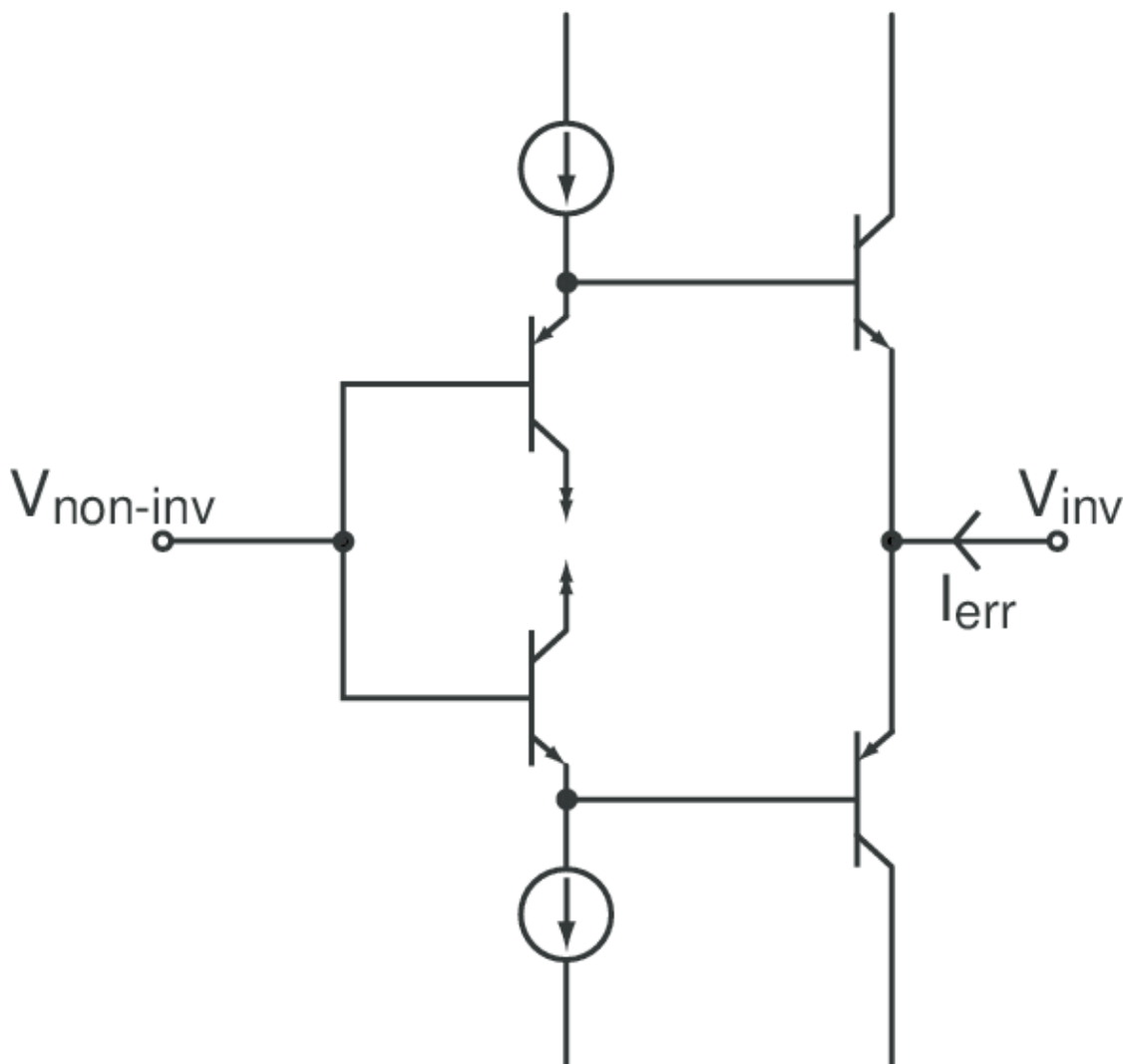

**Figure 6. Typical CFB Amplifier Input Stage**

## 8 Advantages of the CFB Topology

One hidden advantage of current feedback amplifiers is that they usually require fewer internal gain stages than their voltage feedback counterparts. Often a current feedback amplifier consists of merely an input buffer, one gain stage and an output buffer. Having fewer stages means less delay through the open-loop circuit. This translates into higher bandwidths for the same power.

The basic CFB topology in *Figure 7* is a single-stage amplifier. The only high impedance node in the circuit is at the input to the output buffer. VFB amplifiers usually require two or more stages for sufficient loop-gain. These additional stages add delay and yield lower stable bandwidths.

## 9 Distortion

The distortion of an amplifier is impacted by the open-loop distortion of the amplifier and the overall speed of the closed-loop circuit. The amount of open-loop distortion contributed by a CFB amplifier is small due to the basic symmetry of the topology. *Figure 7* illustrates a typical CFB topology. For every NPN transistor, there is a complimentary PNP transistor. Speed is the other main contributor to distortion. In many gain configurations, a CFB amplifier has a greater bandwidth than its VFB counterpart. So at a given signal frequency, the faster part has greater loop-gain and therefore lower distortion.

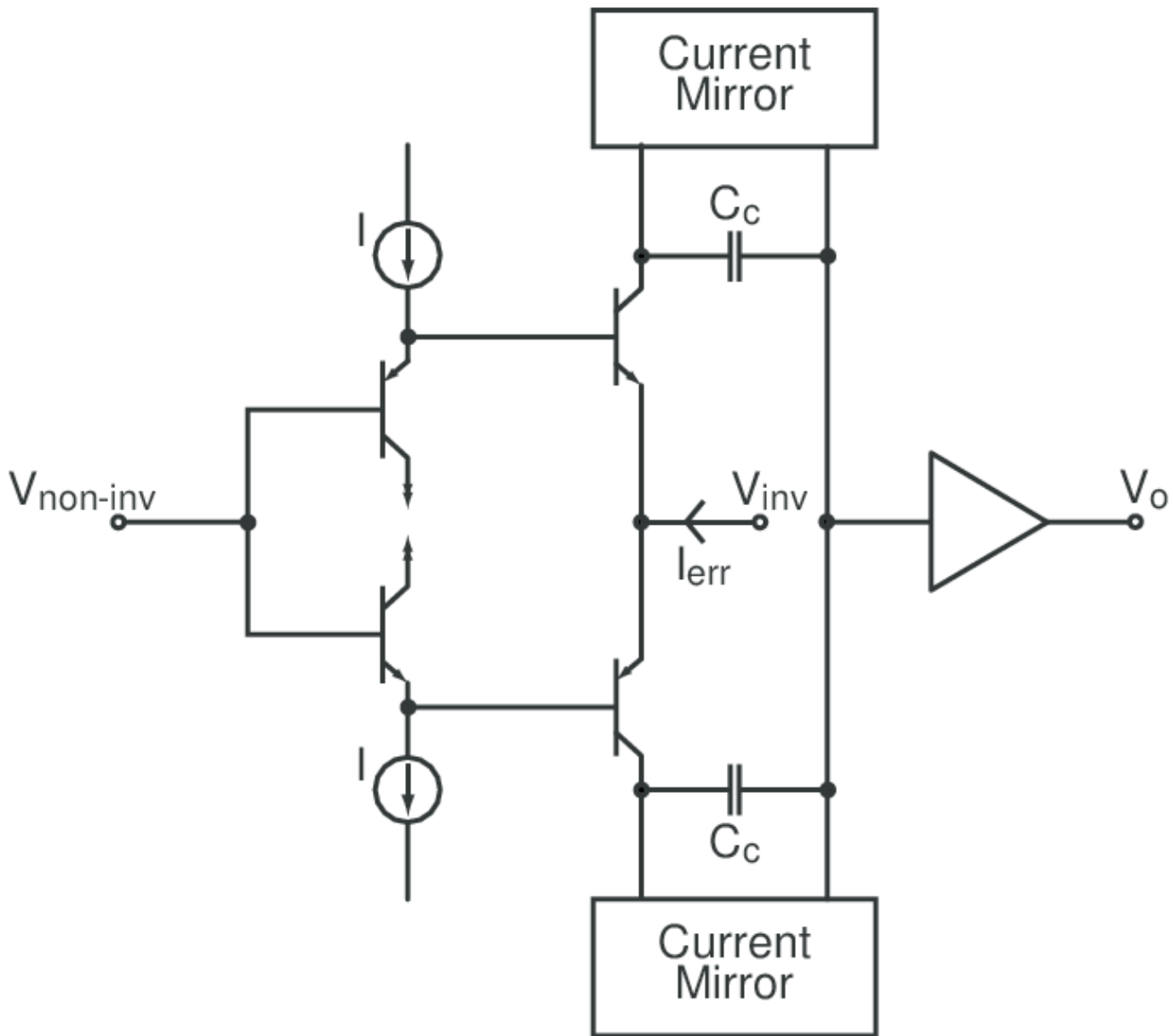

Figure 7. Basic CFB Topology

## 10 Slew Rate

Slew rate performance is also enhanced by the CFB topology. Refer to the typical CFB topology of *Figure 7*. The slew rate is determined by the rate at which the second two transistors can charge the compensation capacitors,  $C_c$ . The current that can be sourced by these transistors is dynamic. It is not limited to any fixed value as is often the case in VFB topologies. With a step input or overload condition, the current flowing through the transistors is increased and the overdriven condition is quickly removed. To the first order, there is no slew rate limit in this architecture. Some VFB amplifiers have input structures similar to CFB amplifiers in order to take advantage of the higher slew rate possibilities. The combination of higher bandwidths and slew rate allows CFB devices to have respectable distortion performance while doing so at a lower power.

The basic current feedback amplifier has no fundamental slew-rate limit. Limits only come about by parasitic transistor capacitances and many strides have been made to reduce even their effects.

The availability of high-speed operational amplifiers in both CFB and VFB topologies allows design engineers to select the best amplifier to fit his/her needs. A CFB amplifier compliments an application that requires high slew rates, low distortion, or the ability to set gain and bandwidth independently. While a VFB amplifier compliments an application where low offset voltage or low noise specifications are required.

## IMPORTANT NOTICE

Texas Instruments Incorporated and its subsidiaries (TI) reserve the right to make corrections, enhancements, improvements and other changes to its semiconductor products and services per JESD46, latest issue, and to discontinue any product or service per JESD48, latest issue. Buyers should obtain the latest relevant information before placing orders and should verify that such information is current and complete. All semiconductor products (also referred to herein as "components") are sold subject to TI's terms and conditions of sale supplied at the time of order acknowledgment.

TI warrants performance of its components to the specifications applicable at the time of sale, in accordance with the warranty in TI's terms and conditions of sale of semiconductor products. Testing and other quality control techniques are used to the extent TI deems necessary to support this warranty. Except where mandated by applicable law, testing of all parameters of each component is not necessarily performed.

TI assumes no liability for applications assistance or the design of Buyers' products. Buyers are responsible for their products and applications using TI components. To minimize the risks associated with Buyers' products and applications, Buyers should provide adequate design and operating safeguards.

TI does not warrant or represent that any license, either express or implied, is granted under any patent right, copyright, mask work right, or other intellectual property right relating to any combination, machine, or process in which TI components or services are used. Information published by TI regarding third-party products or services does not constitute a license to use such products or services or a warranty or endorsement thereof. Use of such information may require a license from a third party under the patents or other intellectual property of the third party, or a license from TI under the patents or other intellectual property of TI.

Reproduction of significant portions of TI information in TI data books or data sheets is permissible only if reproduction is without alteration and is accompanied by all associated warranties, conditions, limitations, and notices. TI is not responsible or liable for such altered documentation. Information of third parties may be subject to additional restrictions.

Resale of TI components or services with statements different from or beyond the parameters stated by TI for that component or service voids all express and any implied warranties for the associated TI component or service and is an unfair and deceptive business practice. TI is not responsible or liable for any such statements.

Buyer acknowledges and agrees that it is solely responsible for compliance with all legal, regulatory and safety-related requirements concerning its products, and any use of TI components in its applications, notwithstanding any applications-related information or support that may be provided by TI. Buyer represents and agrees that it has all the necessary expertise to create and implement safeguards which anticipate dangerous consequences of failures, monitor failures and their consequences, lessen the likelihood of failures that might cause harm and take appropriate remedial actions. Buyer will fully indemnify TI and its representatives against any damages arising out of the use of any TI components in safety-critical applications.

In some cases, TI components may be promoted specifically to facilitate safety-related applications. With such components, TI's goal is to help enable customers to design and create their own end-product solutions that meet applicable functional safety standards and requirements. Nonetheless, such components are subject to these terms.

No TI components are authorized for use in FDA Class III (or similar life-critical medical equipment) unless authorized officers of the parties have executed a special agreement specifically governing such use.

Only those TI components which TI has specifically designated as military grade or "enhanced plastic" are designed and intended for use in military/aerospace applications or environments. Buyer acknowledges and agrees that any military or aerospace use of TI components which have **not** been so designated is solely at the Buyer's risk, and that Buyer is solely responsible for compliance with all legal and regulatory requirements in connection with such use.

TI has specifically designated certain components which meet ISO/TS16949 requirements, mainly for automotive use. Components which have not been so designated are neither designed nor intended for automotive use; and TI will not be responsible for any failure of such components to meet such requirements.

### Products

Audio	<a href="http://www.ti.com/audio">www.ti.com/audio</a>
Amplifiers	<a href="http://amplifier.ti.com">amplifier.ti.com</a>
Data Converters	<a href="http://dataconverter.ti.com">dataconverter.ti.com</a>
DLP® Products	<a href="http://www.dlp.com">www.dlp.com</a>
DSP	<a href="http://dsp.ti.com">dsp.ti.com</a>
Clocks and Timers	<a href="http://www.ti.com/clocks">www.ti.com/clocks</a>
Interface	<a href="http://interface.ti.com">interface.ti.com</a>
Logic	<a href="http://logic.ti.com">logic.ti.com</a>
Power Mgmt	<a href="http://power.ti.com">power.ti.com</a>
Microcontrollers	<a href="http://microcontroller.ti.com">microcontroller.ti.com</a>
RFID	<a href="http://www.ti-rfid.com">www.ti-rfid.com</a>
OMAP Applications Processors	<a href="http://www.ti.com/omap">www.ti.com/omap</a>
Wireless Connectivity	<a href="http://www.ti.com/wirelessconnectivity">www.ti.com/wirelessconnectivity</a>

### Applications

Automotive and Transportation	<a href="http://www.ti.com/automotive">www.ti.com/automotive</a>
Communications and Telecom	<a href="http://www.ti.com/communications">www.ti.com/communications</a>
Computers and Peripherals	<a href="http://www.ti.com/computers">www.ti.com/computers</a>
Consumer Electronics	<a href="http://www.ti.com/consumer-apps">www.ti.com/consumer-apps</a>
Energy and Lighting	<a href="http://www.ti.com/energy">www.ti.com/energy</a>
Industrial	<a href="http://www.ti.com/industrial">www.ti.com/industrial</a>
Medical	<a href="http://www.ti.com/medical">www.ti.com/medical</a>
Security	<a href="http://www.ti.com/security">www.ti.com/security</a>
Space, Avionics and Defense	<a href="http://www.ti.com/space-avionics-defense">www.ti.com/space-avionics-defense</a>
Video and Imaging	<a href="http://www.ti.com/video">www.ti.com/video</a>

### TI E2E Community

[e2e.ti.com](http://e2e.ti.com)