

Technical Information Manual

Revision n. 0
26 September 2003

MOD. V925 series
QUAD LINEAR
FAN IN / FAN OUT

NPO:
00111/02:V925x.MUTx/00

CAEN will repair or replace any product within the guarantee period if the Guarantor declares that the product is defective due to workmanship or materials and has not been caused by mishandling, negligence on behalf of the User, accident or any abnormal conditions or operations.

CAEN declines all responsibility for damages or injuries caused by an improper use of the Modules due to negligence on behalf of the User. It is strongly recommended to read thoroughly the CAEN User's Manual before any kind of operation.



CAEN reserves the right to change partially or entirely the contents of this Manual at any time and without giving any notice.

TABLE OF CONTENTS

1. MODULE DESCRIPTION	4
1.1 OVERVIEW	4
1.2 BLOCK DIAGRAM.....	5
2. TECHNICAL SPECIFICATIONS.....	6
2.1 PACKAGING.....	6
2.2 POWER REQUIREMENTS	6
2.3 FRONT PANEL	7
2.4 MECHANICAL AND ELECTRICAL FEATURES.....	8
2.4.1 <i>Fan in/Fan out sections</i>	8
2.4.2 <i>Discriminator</i>	8
2.5 TECHNICAL SPECIFICATION TABLE	10

LIST OF FIGURES

FIG. 1.1: FAN IN/FAN OUT 4-INPUT SECTION BLOCK DIAGRAM.....	5
FIG. 2.1: FRONT PANEL	7
FIG. 2.2: JUMPERS SETTING.....	9

LIST OF TABLES

TABLE 2.1: POWER REQUIREMENTS	6
TABLE 2.2: FAN IN/FAN OUT TECHNICAL FEATURES.....	10
TABLE 2.3: DISCRIMINATOR CHANNEL TECHNICAL FEATURES	10

1. Module description

1.1 Overview

The Mod. V925 is a 1-unit VME module which houses:

- Three 4 Input + 4 Output Fan in/Fan out sections
- One 3 Input + 3 Output Fan in/Fan out section
- One 1 Channel Discriminator

Each Fan in/Fan out section produces on all its output connectors, the sum of the signals fed to the inputs, multiplied for the selected gain factor (1 or -1 , jumper selectable).

Fan in/Fan out inputs are bipolar, both input and output signals are DC coupled.

Moreover each Fan in/Fan out section features a screwdriver trimmer which allows the DC offset ("zero") adjustment.

The discriminator channel has one DC coupled input, an internal jumper allows to perform the slope coupling on either the leading or the trailing edge; the threshold is screwdriver adjustable and monitorable via test point; the output is NIM standard, its width is screwdriver adjustable as well.

Front panel LEDs allow to monitor all the adjustments performed via internal jumpers.

1.2 Block diagram

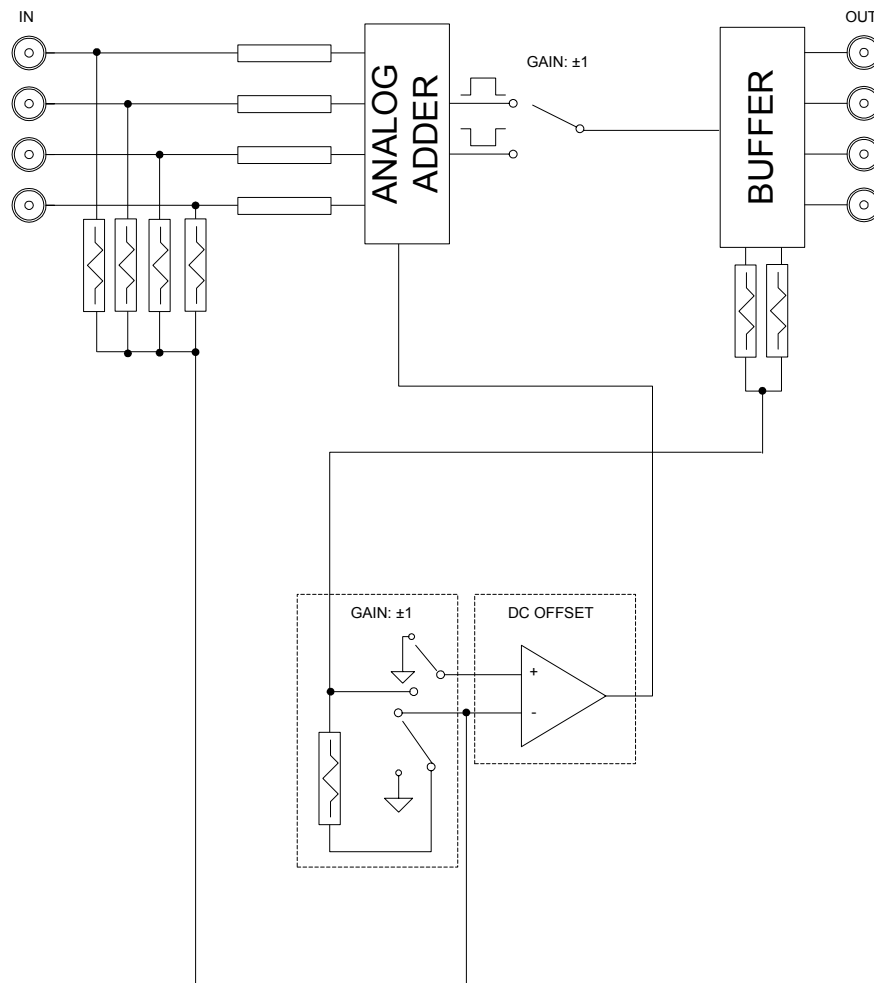

Fig. 1.1: Fan in/Fan out 4-input section block diagram

2. Technical specifications

2.1 Packaging

The module is housed in a 6U-high, 1U-wide VME unit. The board hosts the VME P1 connector.

2.2 Power requirements

The power requirements of the module are as follows:

Table 2.1: Power requirements

+5 V	600 mA
+12 V	70 mA
-12 V	180 mA

2.3 Front panel

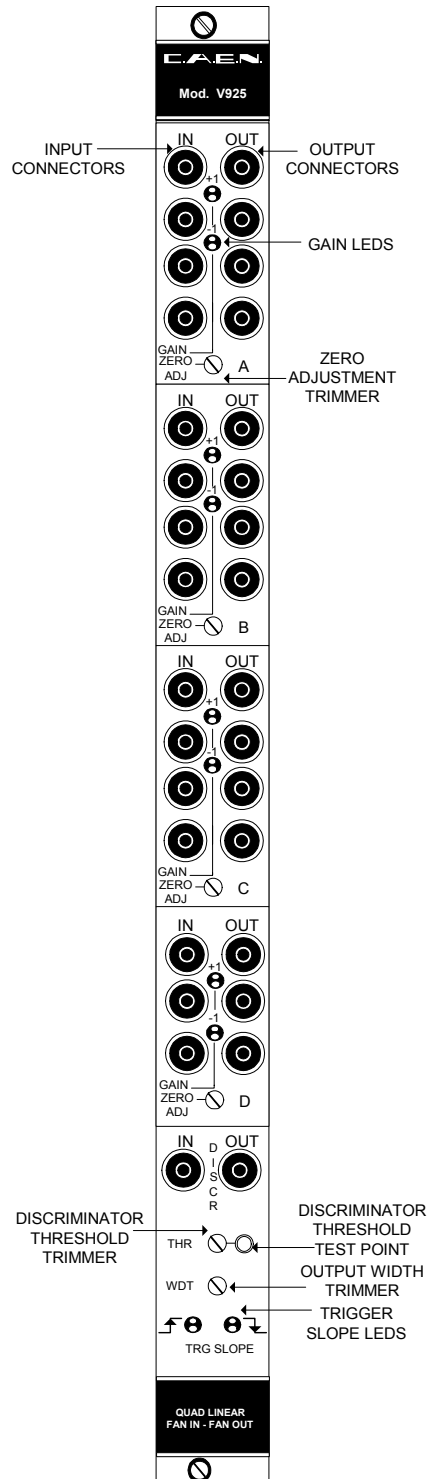

Fig. 2.1: Front panel

2.4 Mechanical and electrical features

2.4.1 Fan in/Fan out sections

INPUT CONNECTORS:	<i>Mechanical specifications:</i> Front panel LEMO 00 type connectors <i>Electrical specifications:</i> Bipolar, DC coupled, 50 Ω impedance
OUTPUT CONNECTORS:	<i>Mechanical specifications:</i> Front panel LEMO 00 type connectors <i>Electrical specifications:</i> DC coupled, provided across 50 Ω loads
ZERO TRIMMER:	<i>Mechanical specifications:</i> Front panel screwdriver trimmer <i>Function:</i> Allows to adjust the output DC offset within a ± 100 mV range
DISPLAYS:	<i>Gain LEDs:</i> 2 Front panel LEDs per section: green: Gain=-1; yellow: Gain=+1.
INTERNAL JUMPERS:	<i>Gain jumper:</i> allows to set gain either at +1 or at -1 (refer to Fig. 2.2)

2.4.2 Discriminator

INPUT CONNECTOR:	<i>Mechanical specifications:</i> Front panel LEMO 00 type connector <i>Electrical specifications:</i> Bipolar, DC coupled, 50 Ω impedance
OUTPUT CONNECTOR:	<i>Mechanical specifications:</i> Front panel LEMO 00 type connector <i>Electrical specifications:</i> Std. NIM level, provided across a 50 Ω load
WIDTH TRIMMER:	<i>Mechanical specifications:</i> Front panel screwdriver trimmer <i>Function:</i> Allows to adjust the output pulse width in the 4÷70 ns/15÷600 ns ranges, jumper selectable (see Fig. 2.2)
THRESHOLD TRIMMER:	<i>Mechanical specifications:</i> Front panel screwdriver trimmer

Function:

Allows to adjust the discriminator threshold in the -1200÷+1200 mV range; one test-point allows to monitor the threshold value

DISPLAYS:

Trigger slope LEDs: 2 Front panel LEDs; the relevant LED lights up according to the trigger slope setting: green: Trailing edge; yellow: Leading edge

INTERNAL JUMPERS:

Trigger slope jumper: allows to set the trigger slope either to leading or to trailing edge
Width range jumper: allows to select the output width range between 4÷70 ns and 15÷600 ns (refer to Fig. 2.2)

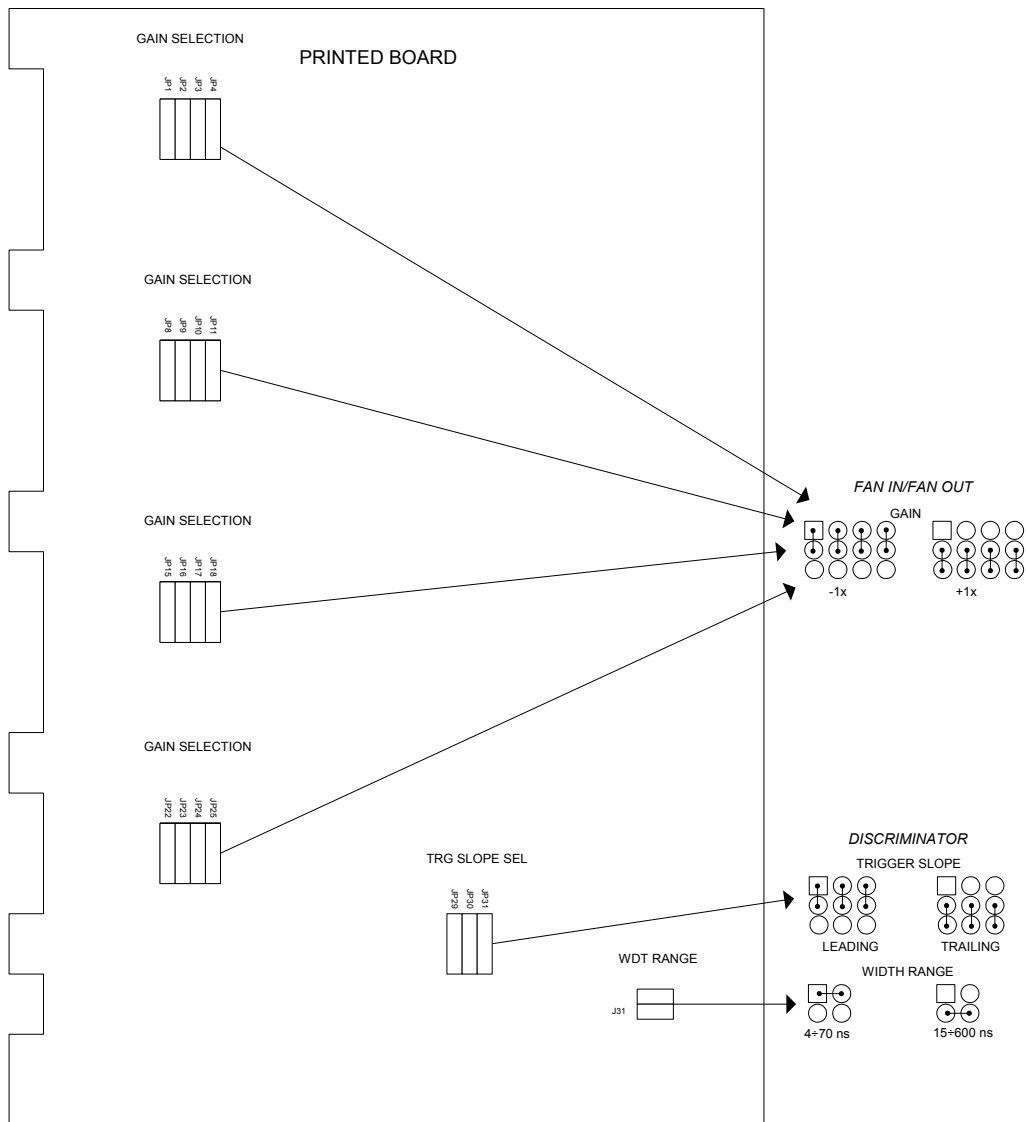

Fig. 2.2: Jumpers setting

2.5 Technical specification table

Table 2.2: Fan in/Fan out technical features

Inputs	bipolar, DC coupled, 50 Ω impedance
Outputs	DC coupled, inverted or non inverted (internal jumper selectable), drive 50 Ω loads
Max. input amplitude	± 1.6 V
Gain	± 1 (internal jumper selectable)
DC offset (Zero) adjustment	± 100 mV
Input reflection	4%
Interchannel insulation	40 dB
Input band width	120 MHz (input: sine wave with 1 V peak-to-peak amplitude)
Integral non-linearity	< 1%
Overload recovery	t.b.d.
DC offset stability	10 μ V/ $^{\circ}$ C
Noise	300 μ V RMS
Input/output delay	4 \pm 1 ns

Table 2.3: Discriminator channel technical features

Input channel	DC coupled on either leading or trailing edge (jumper selectable), 50 Ω
Max. input voltage	± 5 V
Min. detectable signal	± 30 mV
Max. input frequency	160 MHz
Double pulse resolution	6 ns
Threshold range	± 1200 mV
Output channel	Std. NIM level, provided across a 50 Ω load, non updating
Threshold stability	70 μ V/ $^{\circ}$ C
Input/output delay	8 ns
Output width	Dual range: 4÷70 ns/15÷600 ns
Output rise/fall time	1 ns