



# **Technical Information Manual**

**Revision n. 19**

**12 February 2016**

**N1471**

*PROGRAMMABLE HV  
POWER SUPPLY*

CAEN will repair or replace any product within the guarantee period if the Guarantor declares that the product is defective due to workmanship or materials and has not been caused by mishandling, negligence on behalf of the User, accident or any abnormal conditions or operations.

**CAEN declines all responsibility for damages or injuries caused by an improper use of the Modules due to negligence on behalf of the User. It is strongly recommended to read thoroughly the CAEN User's Manual before any kind of operation.**



*CAEN reserves the right to change partially or entirely the contents of this Manual at any time and without giving any notice.*

### **Disposal of the Product**

*The product must never be dumped in the Municipal Waste. Please check your local regulations for disposal of electronics products.*

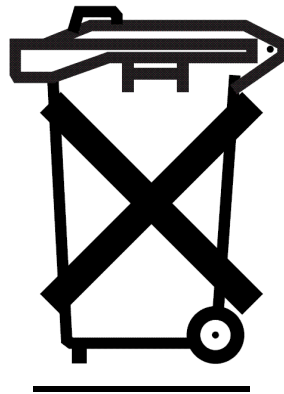

**MADE IN ITALY** : We stress the fact that all the boards are made in Italy because in this globalized world, where getting the lowest possible price for products sometimes translates into poor pay and working conditions for the people who make them, at least you know that who made your board was reasonably paid and worked in a safe environment. (this obviously applies only to the boards marked "MADE IN ITALY", we can not attest to the manufacturing process of "third party" boards).

## TABLE OF CONTENTS

|          |   |           |
|----------|---|-----------|
| <b>1</b> | <b>General description</b> .....                            | <b>5</b>  |
| 1.1      | Overview .....  | 5         |
| <b>2</b> | <b>Technical specifications</b> .....                       | <b>6</b>  |
| 2.1      | Packaging.....  | 6         |
| 2.2      | Power requirements.....                                     | 6         |
| 2.3      | Front and back panel.....                                   | 8         |
| 2.4      | Front panel connections.....                                | 10        |
| 2.4.1    | Local control section.....                                  | 10        |
| 2.4.2    | Channel control section.....                                | 10        |
| 2.4.3    | HV Status control section.....                              | 11        |
| 2.4.3.1  | Alarm signal.....   | 11        |
| 2.4.3.2  | Interlock signal.....                                       | 11        |
| 2.4.4    | Remote communication control section.....                   | 12        |
| 2.5      | Rear panel connections.....                                 | 13        |
| 2.5.1    | HV Channel Output.....                                      | 13        |
| 2.6      | Imon Zoom .....   | 13        |
| 2.7      | Technical specifications table.....                         | 14        |
| <b>3</b> | <b>Operating modes</b> .....                                | <b>15</b> |
| 3.1      | Programmable parameters.....                                | 15        |
| 3.1.1    | Boards parameters.....                                      | 15        |
| 3.1.2    | Channel settings.....                                       | 16        |
| 3.2      | Local Control.....  | 17        |
| 3.2.1    | HV connection.....  | 17        |
| 3.2.2    | Module settings.....  | 18        |
| 3.2.3    | Channel settings.....                                       | 19        |
| 3.2.3.1  | Group Settings.....   | 22        |
| 3.2.3.2  | Smileys.....  | 24        |
| 3.3      | Current monitor offset calibration.....                     | 24        |
| 3.4      | Remote Control.....   | 25        |
| 3.4.1    | Serial Links.....   | 25        |
| 3.4.1.1  | USB communication .....                                     | 25        |
| 3.4.1.2  | RS232 communication.....                                    | 25        |
| 3.4.1.3  | RS485 communication.....                                    | 26        |
| 3.4.1.4  | Ethernet communication .....                                | 26        |
| 3.4.2    | Communication Control.....                                  | 27        |
| 3.4.2.1  | Remote Control: Main Menu .....                             | 27        |
| 3.4.2.2  | Remote Control: General Menu .....                          | 28        |
| 3.4.2.3  | Remote Control: Channels Menu.....                          | 28        |
| 3.4.2.4  | Remote Control: firmw are upgrade.....                      | 29        |
| 3.4.2.5  | Remote Control: format EEPROM .....                         | 30        |
| 3.4.2.6  | Remote Control: Current offset calibration.....             | 30        |
| 3.5      | USB - RS485 Communication Protocol.....                     | 31        |
| 3.5.1    | Command Format.....   | 31        |
| 3.5.2    | Format of response string.....                              | 31        |
| 3.5.3    | MONITOR commands related to the Channels .....              | 32        |
| 3.5.3.1  | Meaning of STATUS bits (value read in decimal Format) ..... | 32        |
| 3.5.4    | MONITOR commands related to the module.....                 | 33        |
| 3.5.4.1  | Meaning of Board Alarm bits.....                            | 34        |
| 3.5.5    | SET commands related to the Channels .....                  | 34        |
| 3.5.6    | SET commands related to the module.....                     | 34        |
| <b>4</b> | <b>Internal Settings</b> .....                              | <b>35</b> |
| 4.1      | Polarity selection .....                                    | 35        |
| 4.2      | Internal switches .....                                     | 37        |
| 4.2.1    | Local Bus termination.....                                  | 37        |
| 4.2.2    | RS485 – RS232 conversion.....                               | 37        |
| 4.3      | Grounding specifications.....                               | 37        |
| 4.3.1    | Safety Earth connection.....                                | 38        |

## LIST OF FIGURES

|           |   |    |
|-----------|---|----|
| Fig. 1.1: | Mod. N1471 4 Channel Programmable HV Power Supply ..... | 5  |
| Fig. 2.1: | Backplane NIM connector.....                            | 7  |
| Fig. 2.2: | Mod. N1471 series front panel (std, A, B, AL, AR) ..... | 8  |
| Fig. 2.3: | Mod. N1471 series back panel (std., A, B) .....         | 9  |
| Fig. 2.4: | Local control panel.....                                | 10 |
| Fig. 2.5: | Channel control panel and Kill scheme.....              | 10 |
| Fig. 2.6: | N1471 HV Status control panel.....                      | 11 |

|   |    |
|---|----|
| Fig. 2.7: N1470 ALAR M electrical scheme.....   | 11 |
| Fig. 2.8: N1470 ALAR M TTL configured.....  | 11 |
| Fig. 2.9: N1470 INTERLOCK electrical scheme.....  | 11 |
| Fig. 2.10: Remote communication control and RS485 I/O – RS232 IN electrical scheme..... | 12 |
| Fig. 2.11: HV Channel panel and test point electrical scheme.....                       | 13 |
| Fig. 3.1: Welcome screen.....   | 17 |
| Fig. 3.2: Channel OFF status screen .....   | 17 |
| Fig. 3.3: Channel ON status screen .....  | 17 |
| Fig. 3.4: Channel KILL status screen .....  | 18 |
| Fig. 3.5: Mode settings status screen.....  | 18 |
| Fig. 3.6: Mode settings access screen.....  | 18 |
| Fig. 3.7: Mode settings edit screen.....  | 18 |
| Fig. 3.8: Channel settings edit screen .....  | 19 |
| Fig. 3.9: Channel VSET select screen .....  | 19 |
| Fig. 3.10: Channel VSET access screen.....  | 19 |
| Fig. 3.11: Channel VSET digit selection screen .....                                    | 19 |
| Fig. 3.12: Channel VSET digit access screen.....  | 20 |
| Fig. 3.13: Channel VSET digit adjust screen .....                                       | 20 |
| Fig. 3.14: Channel VSET digit confirm screen.....                                       | 20 |
| Fig. 3.15: Channel VSET confirm screen .....  | 20 |
| Fig. 3.16: Channel VSET de-selects screen .....   | 21 |
| Fig. 3.17: Channel KILL screen.....   | 21 |
| Fig. 3.18: Channel EXIT screen .....  | 21 |
| Fig. 3.19: Group selection .....  | 22 |
| Fig. 3.20: Group active.....  | 22 |
| Fig. 3.21: Group VSET access screen.....  | 22 |
| Fig. 3.22: Group VSET digit selection screen.....                                       | 22 |
| Fig. 3.23: Group Channel VSET digit access screen .....                                 | 23 |
| Fig. 3.24: Group VSET digit adjust screen .....   | 23 |
| Fig. 3.25: Group VSET digit confirm screen.....   | 23 |
| Fig. 3.26: Channel VSET de-selects screen .....   | 23 |
| Fig. 3.27: Group EXIT screen.....   | 24 |
| Fig. 3.28: USB communication diagram .....  | 25 |
| Fig. 3.29: RS232 communication diagram .....  | 25 |
| Fig. 3.30: RS485 communication diagram .....  | 26 |
| Fig. 3.31: Ethernet communication diagram .....   | 26 |
| Fig. 3.32: RS232 port cable adapter.....  | 27 |
| Fig. 3.33: Main Menu .....  | 27 |
| Fig. 3.34: Board Status Menu.....   | 28 |
| Fig. 3.35: Channels Menu .....  | 28 |
| Fig. 3.36: PC keyboard .....  | 28 |
| Fig. 3.37: Channels group setting.....  | 29 |
| Fig. 3.38: Firmware Upgrade Menu/1.....   | 29 |
| Fig. 3.39: Firmware Upgrade Menu/2.....   | 29 |
| Fig. 3.40: Format EEPROM Menu .....   | 30 |
| Fig. 3.41: Current offset calibration warning .....                                     | 30 |
| Fig. 3.42: Current offset calibration VSET selection.....                               | 30 |
| Fig. 3.43: Current offset calibration confirmation.....                                 | 31 |
| Fig. 4.1: Side cover removal instructions.....  | 35 |
| Fig. 4.2: Polarity selection instructions.....  | 36 |
| Fig. 4.3: Dip switch position .....   | 37 |
| Fig. 4.4: C21 jumper location.....  | 38 |
| Fig. 4.5: Earth configuration connection examples .....                                 | 39 |

## LIST OF TABLES

|  |    |
|--|----|
| Table 1.1: Available items .....                             | 5  |
| Table 2.1: Power requirements .....                          | 6  |
| Table 2.2: Interlock operation.....                          | 12 |
| Table 2.3: Mod. N1471 Channel technical specifications ..... | 14 |
| Table 3.1: Smileys list.....                                 | 24 |

# 1 General description

## 1.1 Overview



Fig. 1.1: Mod. Programmable HV Power Supply

The Mod. N1471 provides 4 independent High Voltage channels in a single width NIM mechanics. Two and one channel versions (N1471A and N1471B) are also available.

Each channel can provide a  $\pm 5.5\text{kV} / 300\ \mu\text{A}$  max output.

Channels have common floating return (common return insulated from the crate ground); HV outputs are delivered through SHV connectors.

The HV output RAMP-UP and RAMP-DOWN rates may be selected independently for each channel in the range  $1\div 500\ \text{V/s}$  in  $1\ \text{V/s}$  steps.

Safety features include:

- OVERVOLTAGE and UNDERVOLTAGE warning when the output voltage differs from the programmed value by more than 2% of set value (minimum 10V).
- Programmable VMAX protection limit
- OVERCURRENT detection: if a channel tries to draw a current larger than its programmed limit, it enters TRIP status, keeping the maximum allowed value for a programmable time (TRIP), before being switched off
- Channels can be enabled or disabled individually through the Interlock logic.

Module control can take place either locally, assisted by a Graphic color display (not available on Mod. N1471AR) or remotely, via USB, RS232 or RS485 (not available on Mod. N1471AL); the RS485 port allows to build a N1471s' daisy chain network (up to 32 modules).

For remote operation, CAEN also provides GECO2020, a graphical application that allows to manage the N14xx HV Power Supplies (as well as all other CAEN Power Supplies).

Moreover, these units can be managed via CAEN HV Wrapper, a set of ANSI C functions bundled in a library, providing the software developer a unified software interface for the control of CAEN Power Supplies. This is a low level application in which the writing of the Control SW is assigned to the user. CAEN HV Wrapper is logically located between a higher level application, such as GECO2020, and the lower layer software libraries. It contains a generic software interface independent by the Power Supply models and by the communication path used to exchange data with them. For more info please visit: [www.caen.it](http://www.caen.it) (products>firmware/software section).

The Mod. A1480 is an optional DC Input Power Equalizer which allows to use a different input power distribution on the N147x modules.

Table 1.1: Available items

| Code         | Item          | Description  |
|--------------|---------------|--|
| WN1471X05AAC | N1471         | 4 Ch NIM Programmable HV Power Supply ( $\pm 5.5\text{kV}$ , $300\ \mu\text{A}$ , $5\text{nA}$ res.) |
| WN1471A05AAC | N1471A        | 2 Ch NIM Programmable HV Power Supply ( $\pm 5.5\text{kV}$ , $300\ \mu\text{A}$ , $5\text{nA}$ res.) |
| WN1471B05AAC | N1471B        | 1 Ch NIM Programmable HV Power Supply ( $\pm 5.5\text{kV}$ , $300\ \mu\text{A}$ , $5\text{nA}$ res.) |
| WA1480AAAAA  | A1480         | DC Power Input Equalizer for N147X Family  |
| WPERS0147001 | Customization | 1mon Zoom x10  |

## 2 Technical specifications

### 2.1 Packaging

The Mod. N1471 boards are housed in single width NIM modules.

### 2.2 Power requirements

Table 2.1: Power requirements

| <b>Board type</b>            | N1471                    |                       |                      |                   |                       |                      |
|------------------------------|--------------------------|-----------------------|----------------------|-------------------|-----------------------|----------------------|
| <b>Channel configuration</b> | <i>without A1480</i>     |                       |                      | <i>with A1480</i> |                       |                      |
|                              | N° ch ON                 | Current ( $\pm 12V$ ) | Current ( $\pm 6V$ ) | n° ch ON          | Current ( $\pm 12V$ ) | Current ( $\pm 6V$ ) |
| 3kV/300 $\mu$ A              | 4 CH                     | 860 mA                | < 10mA               | 4 CH              | 750 mA                | 800 mA               |
| 5.5kV/30 $\mu$ A             | 4 CH                     | 720 mA                | < 10mA               | 4 CH              | 630 mA                | 600 mA               |
| 5.5kV/300 $\mu$ A            | 4 CH                     | 1.02 A                | < 10mA               | 4 CH              | 800 mA                | 900 mA               |
| <b>Board type</b>            | N1471A, N1471AL, N1471AR |                       |                      |                   |                       |                      |
| <b>Channel configuration</b> | <i>without A1480</i>     |                       |                      | <i>with A1480</i> |                       |                      |
|                              | N° ch ON                 | Current ( $\pm 12V$ ) | Current ( $\pm 6V$ ) | n° ch ON          | Current ( $\pm 12V$ ) | Current ( $\pm 6V$ ) |
| 3kV/300 $\mu$ A              | 2 CH                     | 620 mA                | < 10mA               | 2 CH              | 500 mA                | 500 mA               |
| 5.5kV/30 $\mu$ A             | 2 CH                     | 550 mA                | < 10mA               | 2 CH              | 440 mA                | 400 mA               |
| 5.5kV/300 $\mu$ A            | 2 CH                     | 700 mA                | < 10mA               | 2 CH              | 530 mA                | 600 mA               |
| <b>Board type</b>            | N1471B                   |                       |                      |                   |                       |                      |
| <b>Channel configuration</b> | <i>without A1480</i>     |                       |                      | <i>with A1480</i> |                       |                      |
|                              | N° ch ON                 | Current ( $\pm 12V$ ) | Current ( $\pm 6V$ ) | n° ch ON          | Current ( $\pm 12V$ ) | Current ( $\pm 6V$ ) |
| 3kV/300 $\mu$ A              | 1 CH                     | 530 mA                | < 10mA               | 1 CH              | 370 mA                | 400 mA               |
| 5.5kV/30 $\mu$ A             | 1 CH                     | 470 mA                | < 10mA               | 1 CH              | 340 mA                | 300 mA               |
| 5.5kV/300 $\mu$ A            | 1 CH                     | 500 mA                | < 10mA               | 1 CH              | 380 mA                | 400 mA               |

**WARNING:** if the A1480 is not installed,  $\pm 6V$  power supplies are required only by older versions of the N1471; such boards can be recognized by the presence of power pins 10 and 11 on the backplane NIM connector (see figure 2.1). If the A1480 is not installed, new versions operate only with  $\pm 12V$  power supplies.

| PIN | FUNCTION           |
|-----|--------------------|
| 1   | +3 Volts           |
| 2   | -3 Volts           |
| 3   | SPARE              |
| 4   | RESERVED           |
| 5   | COAXIAL            |
| 6   | COAXIAL            |
| 7   | COAXIAL            |
| 8   | +200 Volts D.C.    |
| 9   | SPARE              |
| 10  | +6 Volts           |
| 11  | -6 Volts           |
| 12  | RESERVED           |
| 13  | CARRY NO. 1        |
| 14  | SPARE              |
| 15  | RESERVED           |
| 16  | +12 Volts          |
| 17  | -12 Volts          |
| 18  | SPARE              |
| 19  | RESERVED           |
| 20  | SPARE              |
| 21  | SPARE              |
| 22  | RESERVED           |
| 23  | RESERVED           |
| 24  | RESERVED           |
| 25  | RESERVED           |
| 26  | SPARE              |
| 27  | SPARE              |
| 28  | +24 Volts          |
| 29  | -24 Volts          |
| 30  | SPARE              |
| 31  | CARRY NO. 2        |
| 32  | SPARE              |
| 33  | 117 V.A.C. (HOT)   |
| 34  | POWER RET. GND     |
| 35  | RESET              |
| 36  | GATE               |
| 37  | SPARE              |
| 38  | COAXIAL            |
| 39  | COAXIAL            |
| 40  | COAXIAL            |
| 41  | 117 V.A.C. (NEUT.) |
| 42  | HIGH QUAL. GND     |
| G   | GROUND GUIDE PIN   |

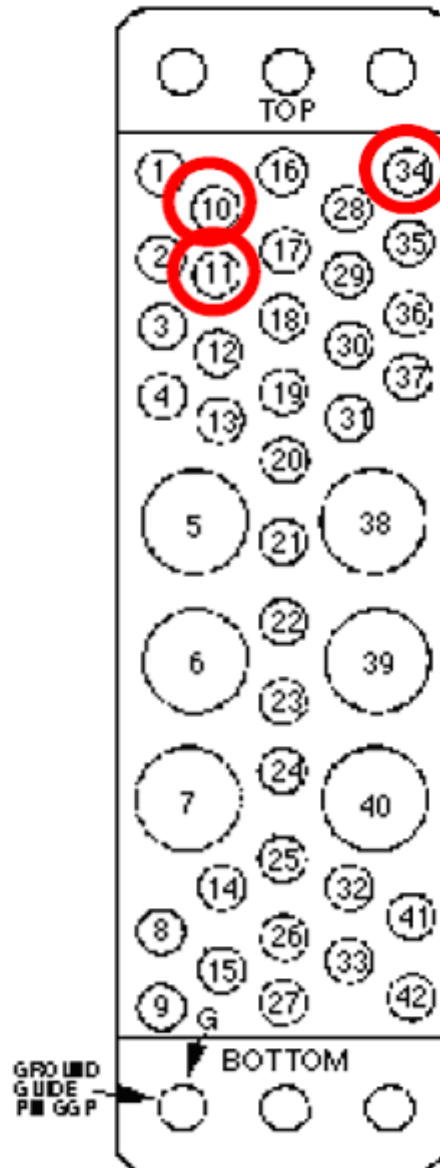

Fig. 2.1: Backplane NIMconnector

## 2.3 Front and back panel

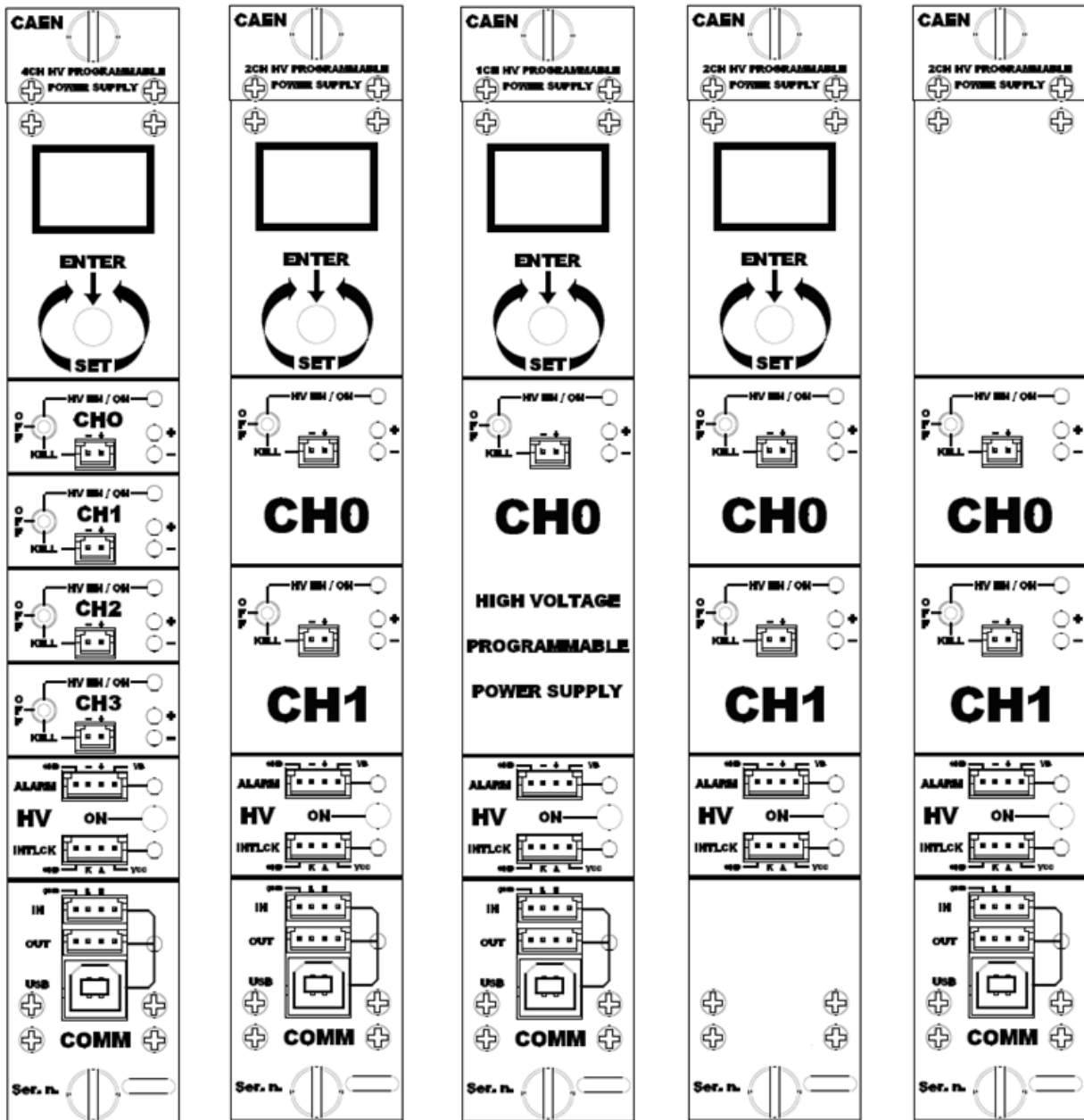

Fig. 2.2: Mod. N1471 series front panel (std, A, B, AL, AR)



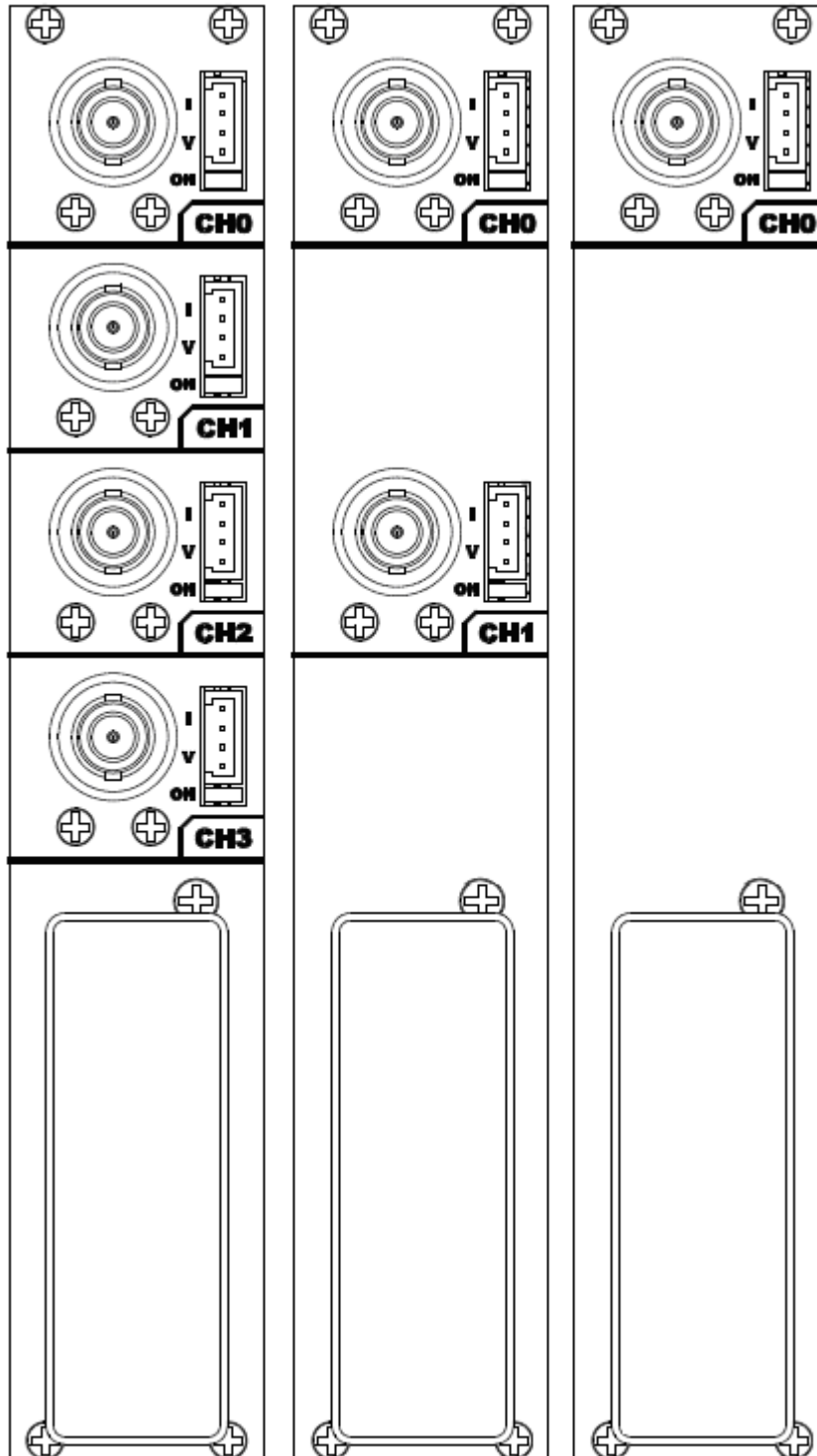

Fig. 2.3: Mod. N1471 series back panel (std., A, B)

## 2.4 Front panel connections

### 2.4.1 Local control section<sup>1</sup>

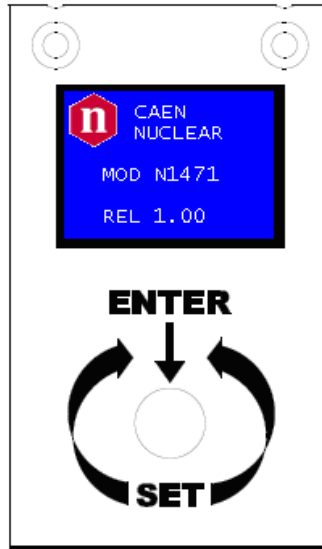

Fig. 2.4: Local control panel

| NAME:   | TYPE:                   | FUNCTION:                  |
|---------|-------------------------|----------------------------|
| MONITOR | 1" OLED DISPLAY (96x64) | Local settings monitoring  |
| TUNE    | ROTARY SWITCH           | Parameter and Mode setting |

### 2.4.2 Channel control section

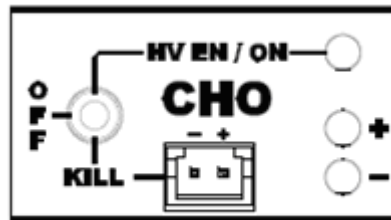

Fig. 2.5: Channel control panel and Kill scheme

| NAME:          | TYPE:         | FUNCTION:  |
|----------------|---------------|--|
| HV_EN/OFF/KILL | 3 POS. SWITCH | Channel Enable and turning OFF/KILL <sup>2</sup>   |
| ON             | RED LED       | HV On enabled  |
| REMOTE KILL    | AMP 280370-2  | The channel is KILLED either as the +/- contacts are open or as a +4±6Vdc voltage is fed to pin - (see note) |
| +              | GREEN LED     | Positive polarity  |
| -              | YELLOW LED    | Negative polarity  |

<sup>1</sup> Not available on Mod. N1471AR

<sup>2</sup> OFF: Channel turned off according to RAMP DOWN setting; KILL: Channel turned off at fastest available rate

### 2.4.3 HV Status control section

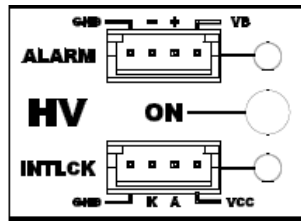

Fig. 2.6: N1471 HV Status control panel

| NAME:     | TYPE:                  | SIGNAL: | FUNCTION:                               |
|-----------|------------------------|---------|---|
| ON        | RED LED                |         | HV On enabled (at least one channel ON) |
| ALARM     | RED LED/ AMP 280371-2. | Out     | Alarm status signaled (active LOW)      |
| INTERLOCK | RED LED/ AMP 280371-2  | In      | Interlock signal                        |

#### 2.4.3.1 Alarm signal

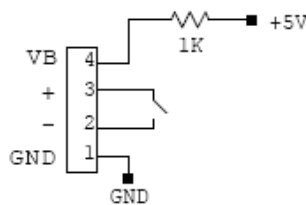

Fig. 2.7: N1470 ALARM electrical scheme

As an Alarm condition is detected (see § 3.5.3.1 and § 3.5.4.1) pins 2 and 3 (- and +) are closed; the contact can be used to switch an external device supplied by an external source, otherwise the VB and GND references can be used to provide a TTL compatible level on pin 2 and 3.

In the first case (externally supplied device) the maximum allowed ratings are:

- Maximum voltage between + and -: 12V
- Maximum sink current across + and -: 100mA

In the latter case, in order to produce a TTL compatible Alarm Out, pin 3 (+) must be connected with pin 4 (VB) and pin 1 (GND) with pin 2 (-); see the diagram below:

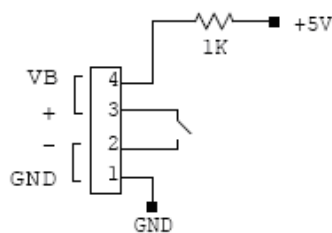

Fig. 2.8: N1470 ALARM TTL configured

#### 2.4.3.2 Interlock signal

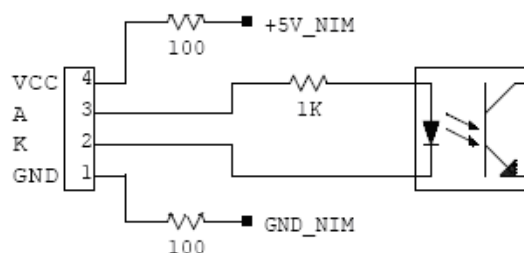

Fig. 2.9: N1470 INTERLOCK electrical scheme

A schematic diagram of the Interlock input is shown in the figure above, where the diode is part of optocoupler stage.

Interlock means that channels are hardware disabled. The interlock operation is explained by the following table:

Table 2.2: Interlock operation

| CONFIGURATION ↓  | INTERLOCK MODE (§ 3.1.1) → | OPEN      | CLOSE     |
|--|----------------------------|-----------|-----------|
| leave contact open   |                            | INTERLOCK | ENABLED   |
| voltage level (0÷1V, ~5mA current) between pin 2 and pin 3 |                            | INTERLOCK | ENABLED   |
| short circuit pin 1 with pin 2, and pin 3 with pin 4       |                            | ENABLED   | INTERLOCK |
| voltage level (4÷6V, ~5mA current) between pin 2 and pin 3 |                            | ENABLED   | INTERLOCK |

The front panel Interlock LED is ON when the INTERLOCK is enabled; as INTERLOCK is enabled, channels are turned off at the fastest available rate, regardless the RAMP DOWN setting.

### 2.4.4 Remote communication control section<sup>3</sup>

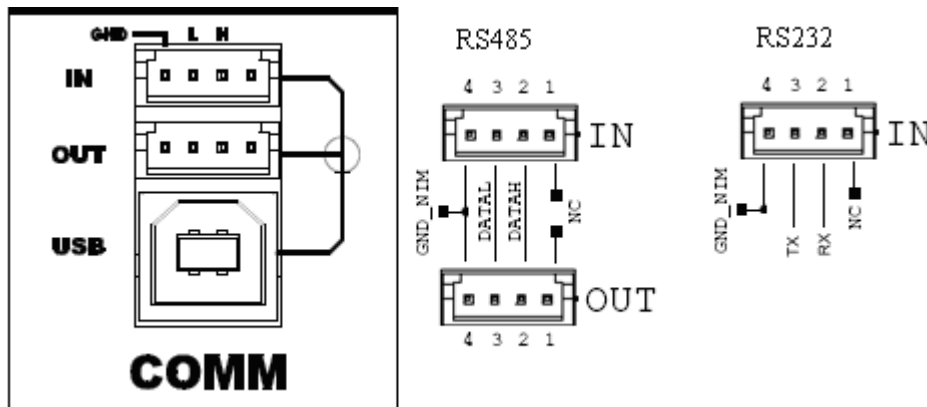

Fig. 2.10: Remote communication control and RS485 I/O– RS232 IN electrical scheme

| NAME: | TYPE:        | FUNCTION:   |
|-------|--------------|---|
| IN    | AMP 280371-2 | RS485 Input <sup>4</sup> ; adaptable to RS232 standard      |
| OUT   | AMP 280371-2 | RS485 Output  |
| USB   | B TYPE USB   | USB2.0 compliant realized via USB ↔ RS232 FT232BM converter |

<sup>3</sup> Not available on Mod. N1471AL

<sup>4</sup> RS 485 Serial Port Interface allows to control up to 32 modules connected by a twisted pair cable; the first and last modules must be terminated, see § 4.2.1.

## 2.5 Rear panel connections

### 2.5.1 HV Channel Output

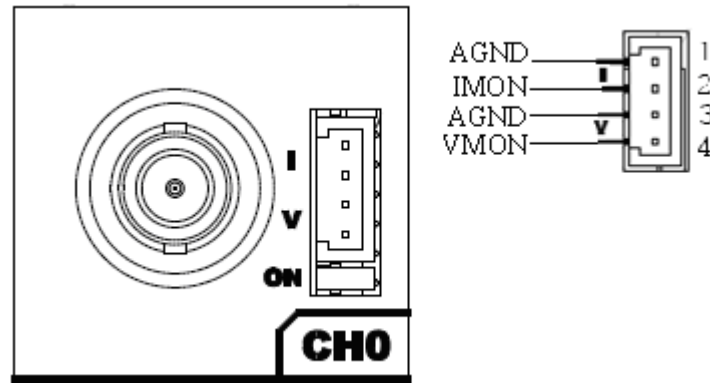

Fig. 2.11: HV Channel panel and test point electrical scheme

| NAME: | TYPE:        | FUNCTION:            |
|-------|--------------|----------------------|
| MON   | AMP 280371-2 | Vout/Iout Test point |
| OUT   | SHV          | HV Channel Output    |

The test points allow to monitor the Channel Output Voltage and Current according to the following conversion:

|                         |  |
|-------------------------|--|
| <b>VMON:</b>            | Voltage level (1V = 1.5 kV $\pm$ 1% readout; same polarity as channel)   |
| <b>IMON high range:</b> | Voltage level (1V = 66 $\mu$ A $\pm$ 3% readout; positive, 0÷5 V range)  |
| <b>IMON low range:</b>  | Voltage level (1V = 6.6 $\mu$ A $\pm$ 3% readout; positive, 0÷5 V range) |

## 2.6 Imon Zoom

Imon Zoom is an optional feature that allows to monitor the channel current with an increased resolution (10x) in the 0–30  $\mu$ A range; if the Imon Zoom is installed, by selecting Imon Range = LOW (see § 3.1.2), the output current is monitored with 0.5nA resolution (instead of 5 nA), in the 0 – 30  $\mu$ A range. It is important to notice that, if Imon Range = LOW is selected, and the channel draws a current larger than 30  $\mu$ A, then Overcurrent is signalled.

## 2.7 Technical specifications table

Table 2.3: Mod. N1471 Channel technical specifications

|   |   |         |
|---|---|---------|
| <b>Output channels:</b>                     | Positive or Negative Polarity (requires internal setting, see § 4.1)  |         |
| <b>Output ranges:</b>                       | 5.5kV / 300µA   |         |
| <b>Max. Ch. Output Power:</b>               | 1.65W   |         |
| <b>Vset / Vmon Resolution:</b>              | 100 mV  |         |
| <b>Iset / Imon Resolution <sup>5</sup>:</b> | If IMON RANGE = High is selected resolution is 5 nA<br>If IMON RANGE = Low is selected resolution is 0.5 nA   |         |
| <b>Vmax:</b>                                | 0 ÷ 5600 V<br>Absolute maximum HV level that the channel is allowed to reach, independently from the preset value Vset. Output voltage cannot exceed the preset value Vmax. The accuracy is 1% ± 5 V  |         |
| <b>Vmax resolution:</b>                     | ± 1 V   |         |
| <b>Alarm output:</b>                        | Open collector, 100 mA maximum sink current   |         |
| <b>Interlock input:</b>                     | LOW: <1V; current~5mA; HIGH: 4÷6 V  |         |
| <b>Ramp Up/Down:</b>                        | 1÷500 Volt/s, 1 Volt/s step   |         |
| <b>Trip:</b>                                | Max. time an "overcurrent" is allowed to last (seconds). A channel in "overcurrent" works as a current generator; output voltage varies in order to keep the output current lower than the programmed value. "Overcurrent" lasting more than set value (1 to 9999) causes the channel to "trip". Output voltage will drop to zero either at the Ramp-down rate or at the fastest available rate, depending on Power Down setting; in both cases the channel is put in the OFF state. If trip= INFINITE, "overcurrent" lasts indefinitely.<br>TRIP range: 0 ÷ 999.9 s; 1000 s = Infinite. Step = 0.1 s |         |
| <b>Vmon vs. Vout Accuracy: <sup>6</sup></b> | ±0.02% of read value ±2V  |         |
| <b>Vset vs. Vmon Accuracy: <sup>4</sup></b> | ±0.02% of read value ±2V  |         |
| <b>Imon vs. Iout Accuracy: <sup>4</sup></b> | If IMON RANGE = High: ±2% of read value ±20nA<br>If IMON RANGE = Low: ±2% of read value ±2nA  |         |
| <b>Iset vs. Imon Accuracy: <sup>4</sup></b> | If IMON RANGE = High: ±2% of read value ±30nA<br>If IMON RANGE = Low: ±2% of read value ±3nA  |         |
| <b>Voltage Ripple:<sup>7</sup></b>          | <b>typical</b>  | <5mVpp  |
|   | <b>maximum</b>  | <10mVpp |
| <b>Humidity range:</b>                      | 0 ÷ 80%   |         |
| <b>Operating temperature:</b>               | 0 ÷ 45°C  |         |
| <b>Storage temperature:</b>                 | -10 ÷ 70°C  |         |
| <b>Vout / Temperature coefficient:</b>      | max. 50ppm / °C   |         |
| <b>Imon / Temperature coefficient:</b>      | max 100ppm/C°; max 300ppm/C° with Imon X10 zoom (optional)  |         |
| <b>Long term stability Vout vs. Vset:</b>   | ± 0.02% (after one week @ constant temperature)   |         |

<sup>5</sup> The module is calibrated by introducing a positive offset on the current monitor, see details in § 3.3

<sup>6</sup> From 10% to 90% of Full Scale Range

<sup>7</sup> Measured with: 1m cable length; 2nF capacitance

### 3 Operating modes

 **CAUTION: N1471 MUST BE USED ONLY IN CRATES WITH FORCED COOLING AIR FLOW!**

Module control can take place either locally, or remotely, via USB or RS485 (see § 3.4).

### 3.1 Programmable parameters







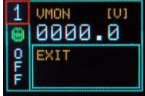

#### 3.1.1 Boards parameters

General board parameters (CONTROL can be operated both in LOCAL and REMOTE mode; other monitor and settings are allowed in LOCAL mode only; see § 3.2) include:

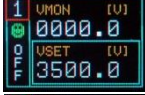
| Parameter:                              | Function:  | Display:  |
|---|--|---|
| Power<br>(Monitor)                      | Module power supply status   |    |
| Termination<br>(Monitor)                | Local Bus termination status (ON/OFF)  |   |
| HV Clock<br>(Monitor)                   | Sync clock frequency (200±10 kHz correct value)  |  |
| Local Bus<br>Baud Rate<br>(Monitor/Set) | 9600, 19200, 38400, 57600, 115200 Baud   |  |
| Local Bus<br>Address<br>(Monitor/Set)   | Local Bus address for remote communication (0÷31)  |  |
| USB Baud<br>Rate<br>(Monitor/Set)       | 9600, 19200, 38400, 57600, 115200 Baud   |  |
| INTERLOCK<br>(Monitor/Set)              | CLOSED / OPEN OPERATION (see § 2.4.3.2)  |  |
| CONTROL<br>(Monitor/Set)                | REMOTE: the module is controlled remotely; local monitor is allowed;<br>LOCAL/REMOTE switch is enabled<br>LOCAL: the module is controlled locally; remote monitor is allowed |  |

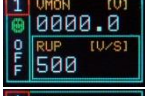
### 3.1.2 Channel settings

For each channel the following parameters can be programmed and monitored either locally or remotely (see § 3.4):

| Parameter:       | Function:  | Unit:        | Display:  |
|------------------|--|--------------|---|
| Vmon             | High Voltage Monitored value   | Volt         |    |
| Imon             | Current Monitored value  | μA           |    |
| V <sub>set</sub> | High Voltage programmed value  | Volt         |    |
| I <sub>set</sub> | Current Limit programmed value   | μA           |    |
| MaxV             | Absolute maximum High Voltage level that the channel is allowed to reach (see § 2.7) | V            |    |
| Ramp-Up          | Maximum High Voltage increase rate   | V/s          |   |
| Ramp-Down        | Maximum High Voltage decrease rate   | V/s          |  |
| Power Down       | Power Down mode after channel TRIP   | KILL or RAMP |  |
| Trip             | Maximum time an "overcurrent" is allowed to last expressed in seconds (see § 2.7)    | s            |  |
| Imon Range       | Current Monitor Zoom 10x (optional)  | H or L       |  |



## 3.2 Local Control

Insert the unit inside a powered NIM crate, and switch it ON. At the power the Display shows for a few seconds the following screen.



Fig. 3.1: Welcome screen

At this point the module is ready to be operated locally. The TUNEROTARY SWITCH (see § 2.4) is lit up as long as Local Control is enabled.

### 3.2.1 HV connection

Verify the channels polarity (polarity setting is explained in § 4.1) checking that the polarity LEDs are switched on according to the programmed configuration (see § 2.4.1); verify the HV\_EN/OFF/KILL 3 POS. SWITCH of each channel is set to OFF; the Display will show the following message in the left lower row:



Fig. 3.2: Channel OFF status screen

now connect the HV cable linking the outputs to the loads to be supplied and enable the HV outputs switching the HV\_EN/OFF/KILL 3 POS. SWITCH in the HV\_EN position; the Display will show the following message in the left lower row:

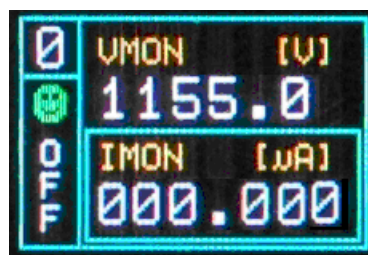

Fig. 3.3: Channel ON status screen

The KILL position of the HV\_EN/OFF/KILL 3 POS. SWITCH allows to turn off the module at the fastest available rate; the Display will show the following message in the left lower row:



Fig. 3.4: Channel KILL status screen

### 3.2.2 Module settings

Module settings are general board settings; turn the TUNE ROTARY SWITCH until this screen is shown:

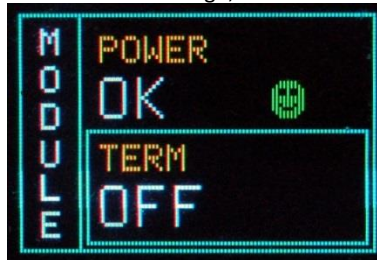

Fig. 3.5: Mode settings status screen

Push the TUNEROTARY SWITCH in order to access MODULE parameters; the MODULE frame becomes red:

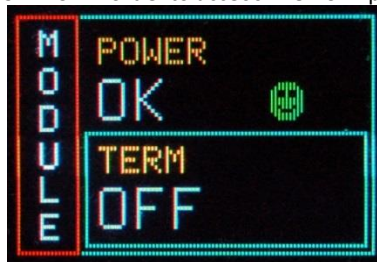

Fig. 3.6: Mode settings access screen

The TUNE ROTARY SWITCH allows to select the parameter to be set; turn the ROTARY SWITCH until such parameter is displayed (for example CONTROL), then select it by pushing the ROTARY SWITCH (the parameter is shown with a red frame as long as it is active):



Fig. 3.7: Mode settings edit screen

Select the desired value by turning the TUNE ROTARY SWITCH and confirm it by pushing the switch itself.

### 3.2.3 Channel settings

In order to operate Output Channel settings:

Turn the TUNE ROTARY SWITCH until the channel number to be set is displayed in the left upper row (for example Channel 0)

Push the TUNE ROTARY SWITCH: at this point the frame of the left upper row (channel number) becomes red and the channel is selected



Fig. 3.8: Channel settings edit screen

Turn the TUNE ROTARY SWITCH until the parameter to be set (for example VSET) is displayed in the right lower row



Fig. 3.9: Channel VSET select screen

Push the TUNE ROTARY SWITCH: at this point the parameter is selected, its frame is shown in red and its name in blue; it is now possible to change the parameters value



Fig. 3.10: Channel VSET access screen

Turn the TUNE ROTARY SWITCH until the value digit to be edited is shown in blue, the parameter name in yellow



Fig. 3.11: Channel VSET digit selection screen

Push the TUNE ROTARY SWITCH: at this point the value digit becomes yellow and can be edited



Fig. 3.12: Channel VSET digit access screen

Turn the TUNE ROTARY SWITCH until the digit reaches the desired value



Fig. 3.13: Channel VSET digit adjust screen

Confirm it by pushing the TUNE ROTARY SWITCH, the edited digit returns blue



Fig. 3.14: Channel VSET digit confirm screen

Once all the digits are set to the desired value, turn the TUNE ROTARY SWITCH until the parameter name returns blue



Fig. 3.15: Channel VSET confirm screen

Push the TUNE ROTARY SWITCH in order to de-select the parameter, the frame returns to blue



Fig. 3.16: Channel VSET de-select screen

It is now possible to set another parameter; note that the POWER DOWN and IMRANGE setting has no digits to be edited, but two options, TRIP/KILL and HIGH/LOW respectively:



Fig. 3.17: Channel KILL screen

In order to access another channel, the EXIT parameter has to be selected



Fig. 3.18: Channel EXIT screen

Now by turning the TUNE ROTARY SWITCH another channel number to be set can be selected. If CONTROL MODE (see § 3.4) is set to REMOTE, the left lower row reports DIS (Disabled), since the channel can be accessed only via the serial links (see § 3.4.1). If the INTERLOCK MODE is changed while one channel is ON, the channel is turned OFF and the left lower row reports ILK (Interlock); if the channel is OFF, it can not be turned ON, until it is enabled according to the Interlock logic (see § 2.4.3.2).

### 3.2.3.1 Group Settings<sup>8</sup>

Group settings allow to broadcast the same parameter value to all channels.

In order to operate Group settings:

Turn the TUNE ROTARY SWITCH until ALL is displayed in the left column



Fig. 3.19: Group selection

Push the TUNEROTARY SWITCH: at this point the frame of the left column becomes red and the GROUP is selected. Turn the TUNE ROTARY SWITCH until the parameter to be set (for example VSET) is displayed in the right column (all four channels values).



Fig. 3.20: Group active

Push the TUNEROTARY SWITCH: at this point the parameter is selected, its frame is shown in red and its name in blue (only one value common to all channels; pre-set value is picked from Channel 0); it is now possible to change the parameters value.



Fig. 3.21: Group VSET access screen

Turn the TUNE ROTARY SWITCH until the value digit to be edited is shown in blue, the parameter name in yellow



Fig. 3.22: Group VSET digit selection screen

<sup>8</sup> Mod. N1471B has not group settings; Mod. N1471A has group settings, 2 channels values are displayed

Push the TUNE ROTARY SWITCH: at this point the value digit becomes yellow and can be edited



Fig. 3.23: Group Channel VSET digitaccess screen

Turn the TUNE ROTARY SWITCH until the digit reaches the desired value



Fig. 3.24: Group VSET digitadjust screen

Confirm it by pushing the TUNE ROTARY SWITCH, the edited digit returns blue



Fig. 3.25: Group VSET digitconfirm screen

Once all the digits are set to the desired value, turn the TUNE ROTARY SWITCH until the parameter name returns blue. Push the TUNE ROTARY SWITCH in order to de-select the parameter, the frame returns to blue; when the parameter is not active, the parameter status of the four channels is shown.



Fig. 3.26: Channel VSET de-select screen

In order to go to individual channel settings, the EXIT parameter has to be selected





Fig. 3.27: Group EXIT screen

### 3.2.3.2 Smileys

Three types of Smileys in the display indicate:

Table 3.1: Smileys list

| Smiley  | Meaning        |
|---|----------------|
|    | OK Status      |
|   | WARNING Status |
|  | ALARM Status   |

## 3.3 Current monitor offset calibration

The module is calibrated by introducing a positive offset on the current monitor. This type of calibration allows to monitor very low current thus removing possible issues due to components and working temperatures related negative offsets. The absolute value of delivered current can be quantified by following the steps below:

- 1) Turn on the module, after a warm-up of about 30 minutes with operating voltage and load disconnected (no link between N1471 and detectors) then read the monitored current value  $I_{mon} = I_1$  (offset)
- 2) Turn off the channel and connect the load
- 3) Turn on the channel with the same voltage set as point 1)
- 4) Wait a few minutes and read again the current value monitor  $I_{mon} = I_2$  (offset +  $I_{out}$ )
- 5) The value of current output is equal to the difference between  $I_2$  and  $I_1$  ( $I_{out} = I_2 - I_1$ )

Leakage currents equal to 1 nA / kV shall be tolerated; e.g.  $V_{out} = 4000V$ ,  $I_{mon} = +6$  nA (2nA Offset + 4nA current leakage/4KV). The offset introduced is equal to 20nA for high range and 2nA for low range with output voltage at 10% of full scale and 20 °C temperature.



## 3.4 Remote Control

Module control can take place remotely, via USB or RS485; the latter allows to build a N1471s' daisy chain network. The CAEN NIM8301 7U 12 Slot Smart Fan Unit 300/600 W Crate allows also to communicate with the module via Ethernet.

### 3.4.1 Serial Links

#### 3.4.1.1 USB communication

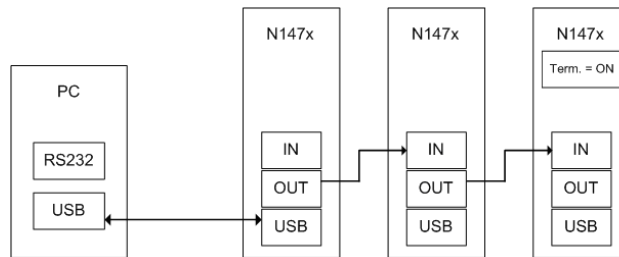

Fig. 3.28: USB communication diagram

The module is provided with a USB2.0 compliant interface (see § 2.4.4). The N1471 can be programmed via PC by connecting the PC USB port with the N1471 USB B-type port; the featured controller, the FT232BM chip requires drivers freely available at [www.ftdichip.com](http://www.ftdichip.com) (Drivers section); the site also provides installation instructions for all OS's (Documents section)

The connection can be performed via terminal emulator, such as HyperTerminal, configured as follows:

- baud rate 9600 (the same set on the N1471! See § 3.2.2)
- Data bits: 8
- Parity: none
- stop bit: 1
- Flow control: Xon Xoff

It is also possible to build a daisy chain of up to 32 N1471's, with the first module connected to the PC USB port and the subsequent ones daisy chained through the COMM IN/OUT, as explained in § ; in this case communication with the chained modules is achieved through the USB- RS485 Communication Protocol, see § 3.5. All modules must be assigned a LOCAL BUS ADDRESS (see § 3.1.1) different from one another and the last one must be terminated (see § 4.2.1).

#### 3.4.1.2 RS232 communication

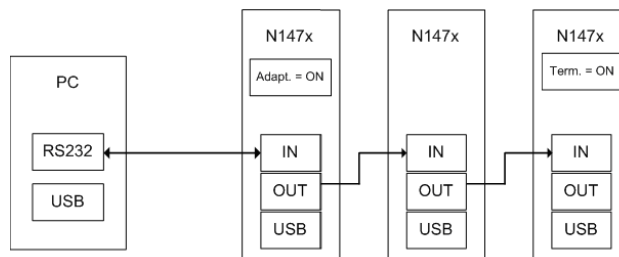

Fig. 3.29: RS232 communication diagram

In order to control the module via RS232 it is necessary to use the module's COMM IN port (refer to § 2.4.2 for RS232 signals) and to follow adaptation instructions (see § 4.2.2).

The connection can be performed via terminal emulator, such as HyperTerminal, configured as follows:

- baud rate 9600 (the same set on the N1471! See § 3.1.1)

- Data bits: 8
- Parity: none
- stop bit: 1
- Flow control: Xon Xoff

It is also possible to build a daisy chain of up to 32 N1471's, with the first module connected to the PC RS232 port and the subsequent ones daisy chained through the COMM IN/OUT, as explained in § 2.4.4; in this case communication with the chained modules is achieved through the USB - RS485 Communication Protocol . All modules must be assigned a LOCAL BUS ADDRESS (see § 3.1.1) different from one another and the last one must be terminated (see § 4.2.1).

### 3.4.1.3 RS485 communication

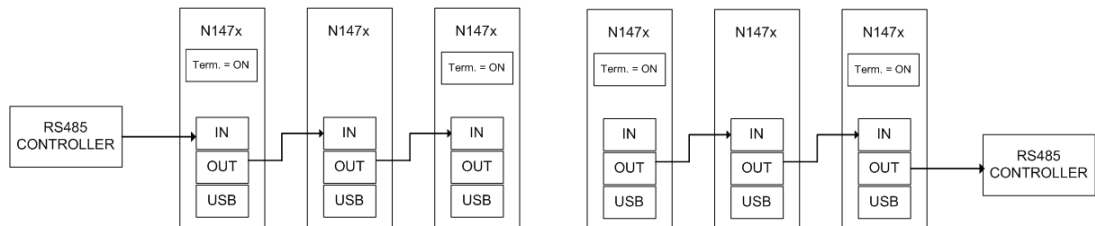

Fig. 3.30: RS485 communication diagram

The COMM IN / OUT connectors implement a RS485 type LOCAL BUS which allows to build a 32 modules daisy chain. This can be achieved through the following steps:

- Connect the connector OUT of a module to corresponding the IN connector of the next one
- Assign to each module a different address (LOCAL BUS ADDR); see § 3.1.1
- Ensure that the LOCAL BUS BIT RATE is the same for all modules; see § 3.1.1
- Terminate the first and the last module in the chain (see § 4.2.1)

The module control can be done in one of the following ways:

- o by connecting a RS485 controller to the first module's COMM IN port
- o by connecting a RS485 controller to the last module's COMM OUT port

Communication with the chained modules is achieved only through the USB - RS485 Communication Protocol, see § 3.4.2.

### 3.4.1.4 Ethernet communication

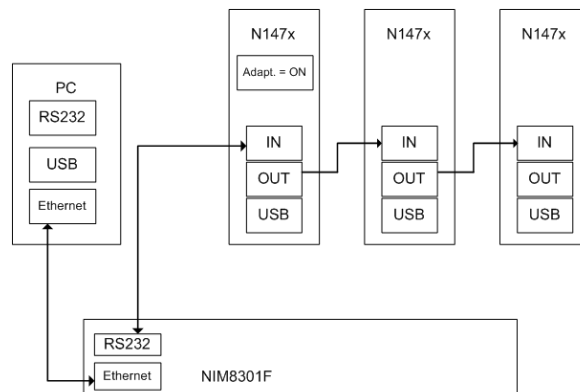

Fig. 3.31: Ethernet communication diagram

It is possible to communicate via Ethernet with one or more daisy chained N1471 modules through the NIM8301 Fan Unit<sup>9</sup>. Communication via Ethernet is possible only through the USB - RS485 Communication Protocol. The single module or the first module of the daisy chain must be connected to the Fan Unit RS232 port through the cable adapter (see figure below) connected to the N1471 COMM IN port; SW[200, 201] switch placed on the Microcontroller board inside the module must be set to Adaptation ON (see § 4).

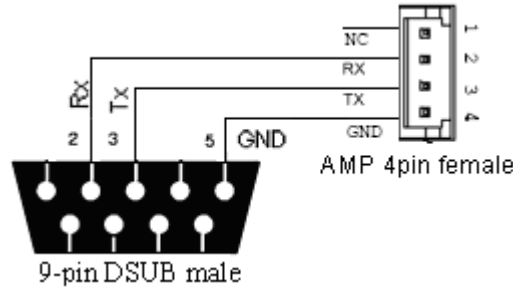

Fig. 3.32: RS232 port cable adapter

### 3.4.2 Communication Control

In order to launch the communication, type *CAEN* and then <Enter>  
As the communication is established, the Main Menu will be displayed.

#### 3.4.2.1 Remote Control: Main Menu

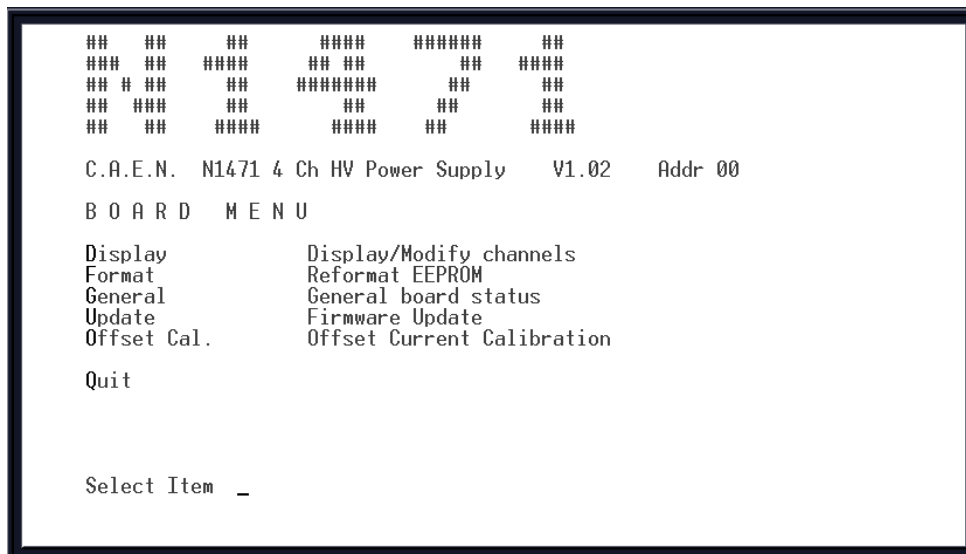

Fig. 3.33: Main Menu

- Type **D** to set/monitor channels parameters
- Type **F** to format the EEPROM
- Type **G** to monitor board status
- Type **U** to upgrade the firmware
- Type **O** to perform the current offset calibration
- Type **Q** to exit the program

<sup>9</sup> The CAEN Mod. NIM8301 is a 7U (5+2) full size NIM crate (19" - 12 slot) available with pluggable 300W and 600W power supplies, ventilated by pluggable 2U fan unit. Remote control and monitoring take place through CAN bus, Ethernet, USB and RS232 interfaces.

### 3.4.2.2 Remote Control: General Menu

By typing **G** it is possible to access the General Menu which includes the board's general settings.

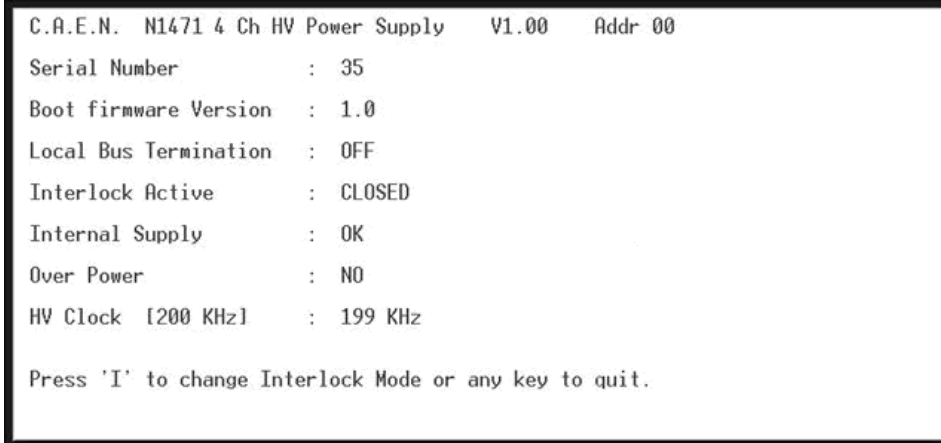

Fig. 3.34: Board Status Menu

### 3.4.2.3 Remote Control: Channels Menu

By typing **D** it is possible to monitor and set all the channels parameters listed in § 3.2.3

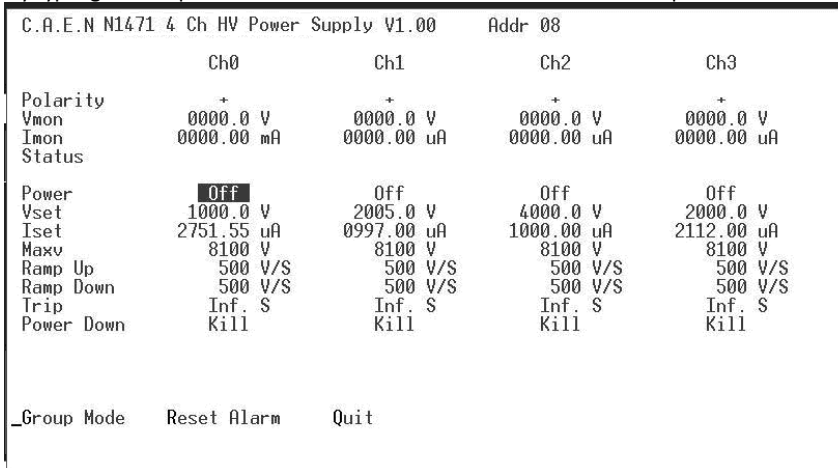

Fig. 3.35: Channels Menu

In order to change one parameter: point the parameter with the arrow keys (see figure below), and type the desired value, confirm by pressing <Enter>; Power and Power Down can be changed using the <Space> bar.

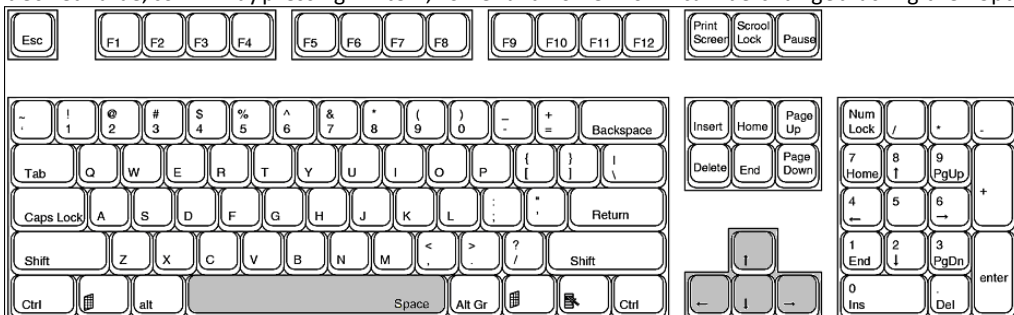

Fig. 3.36: PC keyboard

When one parameter is active, by typing **G** it is possible to make a “group setting”, i.e. broadcast the same value to all channels (the parameter becomes active on all channels, see figure).

| C.A.E.N. N1471 4 Ch HV Power Supply V1.00 Addr 00 |            |            |            |            |
|---|------------|------------|------------|------------|
|   | Ch0        | Ch1        | Ch2        | Ch3        |
| Polarity  | +          | +          | +          | -          |
| Vmon  | 0000.0 V   | 0000.0 V   | 0000.0 V   | 0000.0 V   |
| Imon  | 0000.00 uA | 0000.00 uA | 0000.00 uA | 0000.00 uA |
| Status  | Dis        | Dis        | Dis        | Dis        |
| Power   | Off        | Off        | Off        | Off        |
| Vset  | 1100.0 V   | 1100.0 V   | 1100.0 V   | 1100.0 V   |
| Iset  | 3000.00 uA | 3000.00 uA | 3000.00 uA | 3000.00 uA |
| Maxv  | 8100 V     | 8100 V     | 8100 V     | 8100 V     |
| Ramp Up   | 500 V/S    | 500 V/S    | 500 V/S    | 500 V/S    |
| Ramp Down   | 500 V/S    | 500 V/S    | 500 V/S    | 500 V/S    |
| Trip  | Inf. S     | Inf. S     | Inf. S     | Inf. S     |
| Power Down  | Kill       | Kill       | Kill       | Kill       |
| Imon Range  | High       | High       | High       | High       |
| Group Mode    Reset Alarm    Quit                 |            |            |            |            |

Fig. 3.37: Channels group setting

Type **Q** to exit the Menu.

#### 3.4.2.4 Remote Control: firmware upgrade

By typing **U** it is possible to access the firmware upgrade menu:

| C.A.E.N. N1471 4 Ch HV Power Supply V1.00 Addr 00 |  |  |  |  |
|---|--|--|--|--|
| Firmware Update. Are you sure ? [y/n] _           |  |  |  |  |

Fig. 3.38: Firmware Upgrade Menu/1

If **<y>** is typed, then the following menu is shown:

| C.A.E.N. N1471 4 Ch HV Power Supply V1.00 Addr 00   |  |  |  |  |
|---|--|--|--|--|
| Firmware Update. Are you sure ? [y/n]   |  |  |  |  |
| When the message 'Firmware Updating Complete' is displayed, wait few seconds and then press 'caen'. |  |  |  |  |
| Resetting ..  |  |  |  |  |
| Flash Erasing ...   |  |  |  |  |
| Ready to receive  |  |  |  |  |
| Please send the new firmware  |  |  |  |  |

Fig. 3.39: Firmware Upgrade Menu/2

At this point it is necessary to upload the updated firmware.

If "HyperTerminal" is used it is necessary to perform "Transfer" and "Send Text File" operations by selecting the file "N1471.xxx"

### 3.4.2.5 Remote Control: format EEPROM

By typing **F** it is possible to access the format EEPROM menu:

```
C.A.E.N. N1471 4 Ch HV Power Supply V1.00

Format EEPROM. Are you sure ? [y/n]
```

Fig. 3.40: Format EEPROM Menu

After the FORMAT command, all the channels have the following settings:

Vset = 0V  
Iset = 31.0  $\mu$ A  
Ramp Up / Down = 50V/s  
Trip = 10s  
MaxV = 5600V  
Power Down = Kill

Module setting:  
Interlock Mode = Active CLOSED

### 3.4.2.6 Remote Control: Current offset calibration

By typing **O** it is possible to perform the current offset calibration (the calibration must be performed after 30 minutes operation at least); it is necessary to perform a calibration anytime external operating conditions change; the following instructions are displayed:

```
C.A.E.N. N1471 4 Ch HV Power Supply V1.02 Addr 00

*** NO LOAD CURRENT CALIBRATION ***

!!! WARNING !!!

For this calibration all channels MUST be OFF
and disconnected from any load.

Are you sure ? [y/n] _
```

Fig. 3.41: Current offset calibration warning

Once channels are off and disconnected from the load, type **y**; at this point the program asks for the current value (VSET) selected for the offset compensation, such value is common to all channels; factory calibration is performed at 1000V, type VSET then press <ENTER>

```
C.A.E.N. N1471 4 Ch HV Power Supply V1.03 Addr 00

*** NO LOAD IMON CALIBRATION ***

Enter VSET : _
```

Fig. 3.42: Current offset calibration VSET selection

the calibration is performed and the program asks for coefficients to be saved.

```
C.A.E.N. N1471 4 Ch HV Power Supply V1.02 Addr 00
*** NO LOAD CURRENT CALIBRATION ***
Wait for channel Off ...
Step 1 ... [00 s]
Step 2 ... [00 s]
Press '0' to exit or any key to save coefficients._
```

Fig. 3.43: Current offset calibration confirmation

### 3.5 USB - RS485 Communication Protocol

The following Protocol allows to communicate with up to 32 daisy chained modules. The Protocol is based on commands made of ASCII characters strings. The protocol requires firmware revision 1.0.1 or greater.

#### 3.5.1 Command Format

The Format of a command string is the following :

**\$BD:\*\* ,CMD:\*\*\* ,CH\* ,PAR:\*\*\* ,VAL:\*\*\* ,\*\* <CR, LF >**

The fields that form the command are :

**BD : 0..31** module address (to send the command)

**CMD : MON, SET**

**CH : 0..4** (4 for the commands related to all Channels)

**PAR :** (see parameters tables)

**VAL :** (numerical value must have a Format compatible with resolution and range)

#### 3.5.2 Format of response string

Format response in case of error

| String          | Function (Units)  |
|-----------------|---|
| #BD:** ,CMD:ERR | Wrong command Format or command not recognized          |
| #BD:** ,CH:ERR  | Channel Field not present or wrong Channel value        |
| #BD:** ,PAR:ERR | Field parameter not present or parameter not recognized |
| #BD:** ,VAL:ERR | Wrong set value (<Min or >Max)                          |
| #BD:** ,LOC:ERR | Command SET with module in LOCAL mode                   |

Each string is terminated by < CR, LF >

Format response in case of correct command

| String                            | Function (Units)  |
|-----------------------------------|---|
| #BD:** ,CMD:OK                    | command Ok  |
| #BD:** ,CMD:OK ,VAL:***           | command Ok *** = value for command to individual Channel                |
| #BD:** ,CMD:OK ,VAL:*** ,*** ,*** | command Ok *** ,*** ,*** = values Ch0,1,2,3 for command to all Channels |

Numerical value Field 'VAL' has Format compatible (comma and decimal part) with the resolution and the range related to the parameter.

Each string is terminated by < CR, LF >

### 3.5.3 MONITOR commands related to the Channels

The following table contains the strings to be used to handle monitor commands related to the Channels. The 'X' in the Field 'Channel' can be set in the '0..4' range.

When 'X=4' the module returns the values of the parameter of all 4 Channels.

| String                           | Function (Units)                                      |
|----------------------------------|---|
| \$BD:xx,CMD:MON,CH:X,PAR:VSET    | Read out VSET value ( XXXX.X V )                      |
| \$BD:xx,CMD:MON,CH:X,PAR:VMIN    | Read out VSET minimum value ( 0 V )                   |
| \$BD:xx,CMD:MON,CH:X,PAR:VMAX    | Read out VSET maximum value ( 8000.0 V )              |
| \$BD:xx,CMD:MON,CH:X,PAR:VDEC    | Read out VSET number of decimal digits                |
| \$BD:xx,CMD:MON,CH:X,PAR:VMON    | Read out VMON value ( XXXX.X V )                      |
| \$BD:xx,CMD:MON,CH:X,PAR:ISET    | Read out ISET value ( XXXX.XX $\mu$ A )               |
| \$BD:xx,CMD:MON,CH:X,PAR:IMIN    | Read out ISET minimum value ( 0 $\mu$ A )             |
| \$BD:xx,CMD:MON,CH:X,PAR:IMAX    | Read out ISET maximum value ( 3000.00 $\mu$ A )       |
| \$BD:xx,CMD:MON,CH:X,PAR:ISDEC   | Read out ISET number of decimal digits                |
| \$BD:xx,CMD:MON,CH:X,PAR:IMON    | Read out IMON value ( XXXX.XX $\mu$ A )               |
| \$BD:xx,CMD:MON,CH:X,PAR:IMRANGE | Read out IMON RANGE value ( HIGH / LOW )              |
| \$BD:xx,CMD:MON,CH:X,PAR:IMDEC   | Read out IMON number of decimal digits ( 2 HR, 3 LR ) |
| \$BD:xx,CMD:MON,CH:X,PAR:MAXV    | Read out MAXVSET value ( XXXX V )                     |
| \$BD:xx,CMD:MON,CH:X,PAR:MVMIN   | Read out MAXVSET minimum value ( 0 V )                |
| \$BD:xx,CMD:MON,CH:X,PAR:MVMAX   | Read out MAXVSET maximum value ( 8100 V )             |
| \$BD:xx,CMD:MON,CH:X,PAR:MVDEC   | Read out MAXVSET number of decimal digits             |
| \$BD:xx,CMD:MON,CH:X,PAR:RUP     | Read out RAMP UP value ( XXX V/S )                    |
| \$BD:xx,CMD:MON,CH:X,PAR:RUPMIN  | Read out RAMP UP minimum value ( 1 V/S )              |
| \$BD:xx,CMD:MON,CH:X,PAR:RUPMAX  | Read out RAMP UP maximum value ( 500 V/S )            |
| \$BD:xx,CMD:MON,CH:X,PAR:RUPDEC  | Read out RAMP UP number of decimal digits             |
| \$BD:xx,CMD:MON,CH:X,PAR:RDW     | Read out RAMP DOWN value ( XXX V/S )                  |
| \$BD:xx,CMD:MON,CH:X,PAR:RDWMIN  | Read out RAMP DOWN minimum value ( 1 V/S )            |
| \$BD:xx,CMD:MON,CH:X,PAR:RDWMAX  | Read out RAMP DOWN maximum value ( 500 V/S )          |
| \$BD:xx,CMD:MON,CH:X,PAR:RDWDEC  | Read out RAMP DOWN number of decimal digits           |
| \$BD:xx,CMD:MON,CH:X,PAR:TRIP    | Read out TRIP time value ( XXXX.X S )                 |
| \$BD:xx,CMD:MON,CH:X,PAR:TRIPMIN | Read out TRIP time minimum value ( 0 S )              |
| \$BD:xx,CMD:MON,CH:X,PAR:TRIPMAX | Read out TRIP time maximum value ( 1000.0 S )         |
| \$BD:xx,CMD:MON,CH:X,PAR:TRIPDEC | Read out TRIP time number of decimal digits           |
| \$BD:xx,CMD:MON,CH:X,PAR:PDWN    | Read out POWER DOWN value ( RAMP / KILL )             |
| \$BD:xx,CMD:MON,CH:X,PAR:POL     | Read out POLARITY value ( '+' / '-' )                 |
| \$BD:xx,CMD:MON,CH:X,PAR:STAT    | Read out Channel status value ( XXXXX )               |

#### 3.5.3.1 Meaning of STATUS bits (value read in decimal Format)

| Bit        | Function       |
|------------|----------------|
| Bit 0 → ON | 1 : ON 0 : OFF |



|                   |  |
|-------------------|--|
| Bit 1 → RUP       | 1 : Channel Ramp UP                                      |
| Bit 2 → RDW       | 1 : Channel Ramp DOWN                                    |
| Bit 3 → OVC       | 1 : IMON >= ISET   |
| Bit 4 → OV        | 1 : VMON > VSET + 250 V                                  |
| Bit 5 → UNV       | 1 : VMON < VSET - 250 V                                  |
| Bit 6 → MAXV      | 1 : VOUT in MAXV protection                              |
| Bit 7 → TRIP      | 1 : Ch OFF via TRIP (Imon >= Iset during TRIP)           |
| Bit 8 → OVP       | 1 : Power Max; Power Out > 1.7W                          |
| Bit 9 → OVT       | 1: TEMP > 105°C  |
| Bit 10 → DIS      | 1 : Ch disabled (REMOTE Mode and Switch on OFF position) |
| Bit 11 → KILL     | 1 : Ch in KILL via front panel                           |
| Bit 12 → ILK      | 1 : Ch in INTERLOCK via front panel                      |
| Bit 13 → NOCAL    | 1 : Calibration Error                                    |
| Bit 14, 15 → N.C. |  |

### 3.5.4 MONITOR commands related to the module

The following table shows the strings to be used to handle monitor commands related to the module.

| String                      | Function (Units)                                 |
|-----------------------------|--|
| \$BD:xx,CMD:MON,PAR:BDNAME  | Read out module name ( N1471 )                   |
| \$BD:xx,CMD:MON,PAR:BDNCH   | Read out number of Channels present ( 4 )        |
| \$BD:xx,CMD:MON,PAR:BDFREL  | Read out Firmware Release ( XX.X )               |
| \$BD:xx,CMD:MON,PAR:BDSNUM  | Read out value serial number ( XXXXX )           |
| \$BD:xx,CMD:MON,PAR:BDILK   | Read out INTERLOCK status ( YES/NO )             |
| \$BD:xx,CMD:MON,PAR:BDILKM  | Read out INTERLOCK mode ( OPEN/CLOSED )          |
| \$BD:xx,CMD:MON,PAR:BDCTR   | Read out Control Mode ( LOCAL / REMOTE )         |
| \$BD:xx,CMD:MON,PAR:BDTERM  | Read out LOCAL BUS Termination status ( ON/OFF ) |
| \$BD:xx,CMD:MON,PAR:BDALARM | Read out Board Alarm status value ( XXXXX )      |

### 3.5.4.1 Meaning of Board Alarm bits

| Bit              | Function   |
|------------------|--|
| Bit 0 → CH0      | 1 : Ch0 in Alarm status                                    |
| Bit 1 → CH1      | 1 : Ch1 in Alarm status                                    |
| Bit 2 → CH2      | 1 : Ch2 in Alarm status                                    |
| Bit 3 → CH3      | 1 : Ch3 in Alarm status                                    |
| Bit 4 → PWFAIL   | 1 : Board in POWER FAIL                                    |
| Bit 5 → OVP      | 1 : Board in OVER POWER                                    |
| Bit 6 → HVCKFAIL | 1 : Internal HV Clock FAIL ( $\neq 200 \pm 10\text{kHz}$ ) |

### 3.5.5 SET commands related to the Channels

The following table contains the strings to be used to handle set commands related to the Channels. The 'X' in the Field 'Channel' can be set to the '0..(N-1)' values.<sup>10</sup> When 'X=N' the command is issued to all Channels.

| String  | Function (Units)                   |
|---|------------------------------------|
| \$BD:xx,CMD:SET,CH:X,PAR:VSET,VAL:XXXX.X      | Set VSET value                     |
| \$BD:xx,CMD:SET,CH:X,PAR:ISET,VAL:XXXX.XX     | Set ISET value                     |
| \$BD:xx,CMD:SET,CH:X,PAR:MAXV,VAL:XXXX        | Set MAXVSET value                  |
| \$BD:xx,CMD:SET,CH:X,PAR:RUP,VAL:XXX          | Set RAMP UP value                  |
| \$BD:xx,CMD:SET,CH:X,PAR:RDW,VAL:XXX          | Set RAMP DOWN value                |
| \$BD:xx,CMD:SET,CH:X,PAR:TRIP,VAL:XXXX.X      | Set TRIP time value                |
| \$BD:xx,CMD:SET,CH:X,PAR:PDWN,VAL:RAMP/KILL   | Set POWER DOWN mode value          |
| \$BD:xx,CMD:SET,CH:X,PAR:IMRANGE,VAL:HIGH/LOW | Set IMON RANGE value <sup>11</sup> |
| \$BD:xx,CMD:SET,CH:X,PAR:ON                   | Set Ch ON                          |
| \$BD:xx,CMD:SET,CH:X,PAR:OFF                  | Set Ch OFF                         |

### 3.5.6 SET commands related to the module

| String                                     | Function (Units)   |
|--|--------------------|
| \$BD:xx,CMD:SET,PAR:BDILKM,VAL:OPEN/CLOSED | Set Interlock Mode |
| \$BD:xx,CMD:SET,PAR:BDCLR                  | Clear alarm signal |

<sup>10</sup> N is the number of channels

<sup>11</sup> parameter 'IMRANGE' can be changed only on modules featuring IMON zoom (optional)

## 4 Internal Settings

### 4.1 Polarity selection

The output polarity is independently selectable for each channel. Note that the polarity is indicated by two LEDs for each channel on the front panel.

In order to change the polarity:

- Wear Antistatic Gloves
- Switch off the unit
- Wait for the complete discharge of the capacitors.
- Lay down the unit, right side up
- Remove screws 1, 2, 3, 4, 5, 6, see figure (red):

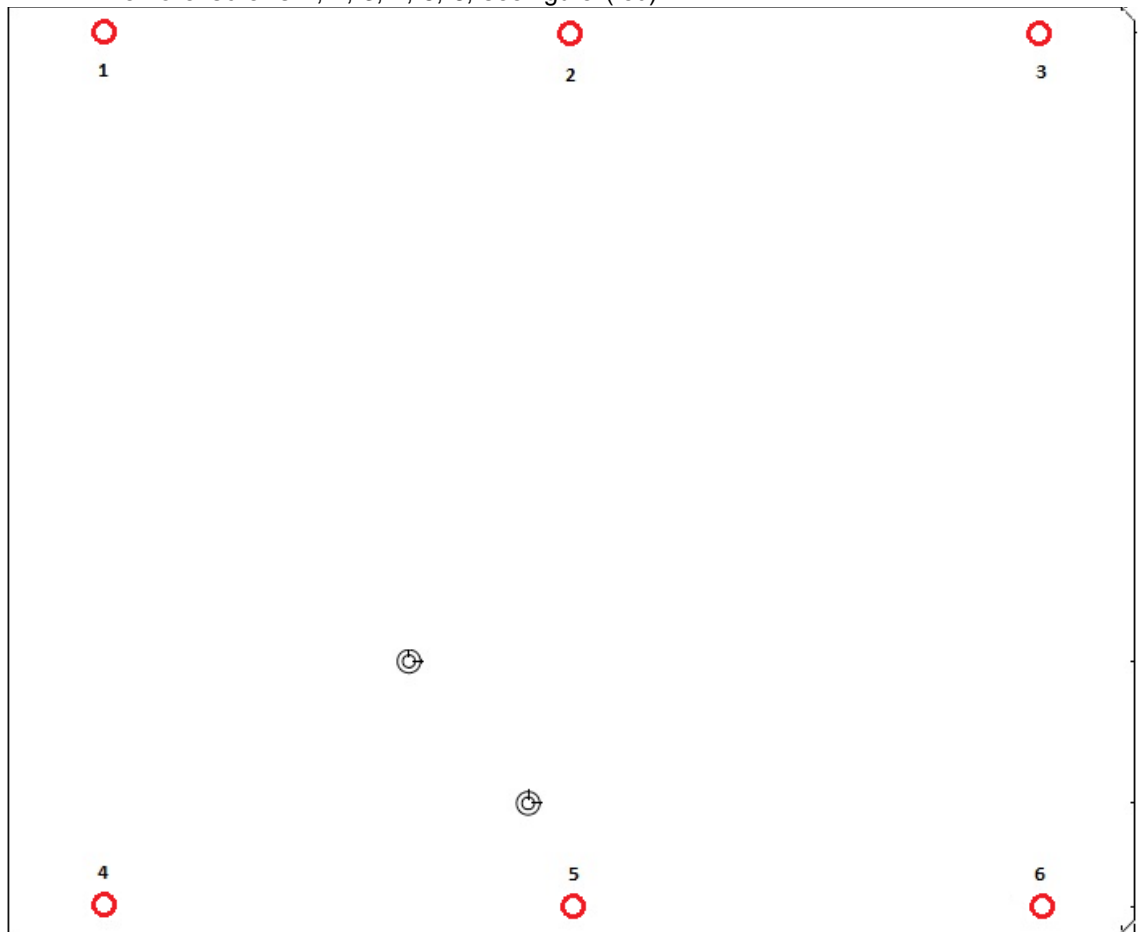

*Fig. 4.1: Side cover removal instructions*

- Lift the side cover gently
- At this point it is possible to change the channel polarity: refer to the following figure (the blue arrow indicates diode bridge box placed to configure channel as POSITIVE).
- During this operation pay attention not to bend the pins, as they are plugged completely in their sockets

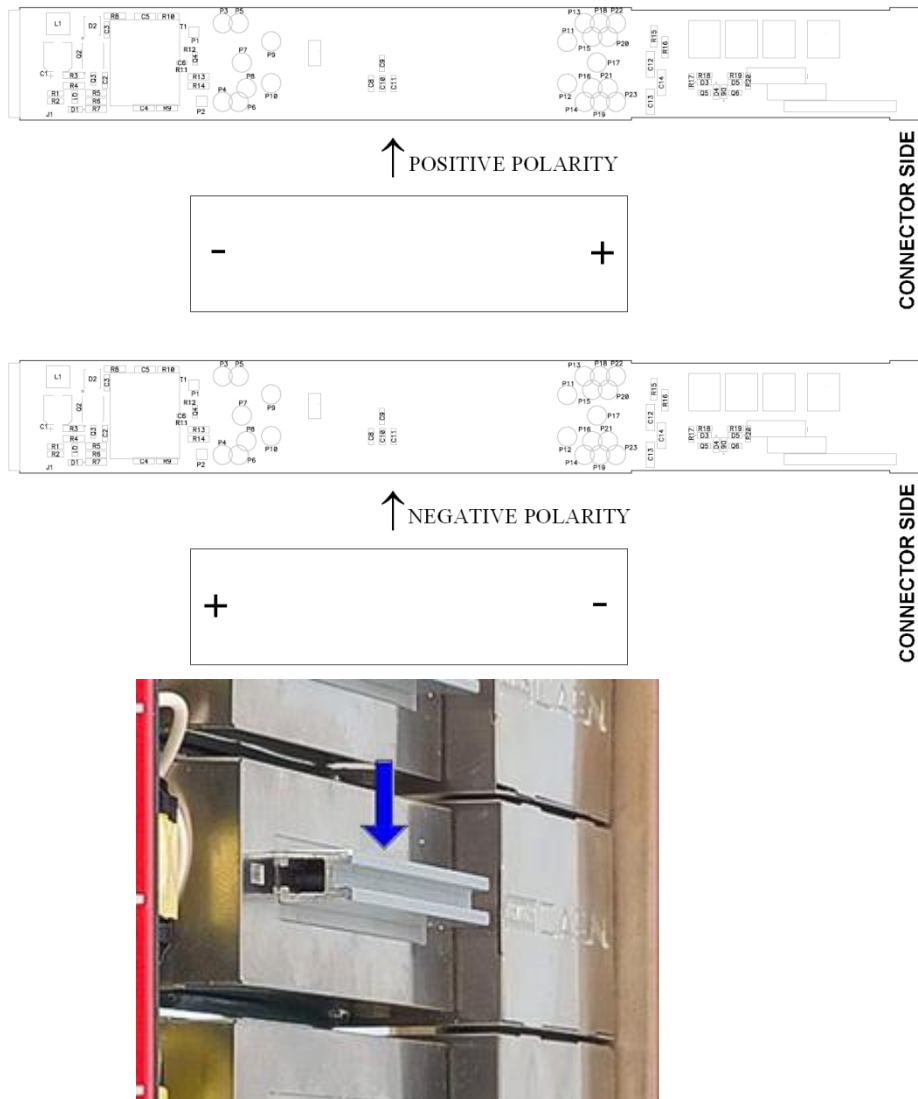

Fig. 4.2: Polarity selection instructions

- In order to choose the POSITIVE POLARITY, plug the diode bridge box, with the + symbol towards the connector side.
- In order to choose the NEGATIVE POLARITY, plug the diode bridge box, with the - symbol towards the connector side.
- Always pull and plug the diode bridge box by holding it on the handle pointed by the arrow in Fig. above.

Once settings are done, put the right side cover back in place with screws 1, 2, 3, 4, 5, 6.

## 4.2 Internal switches

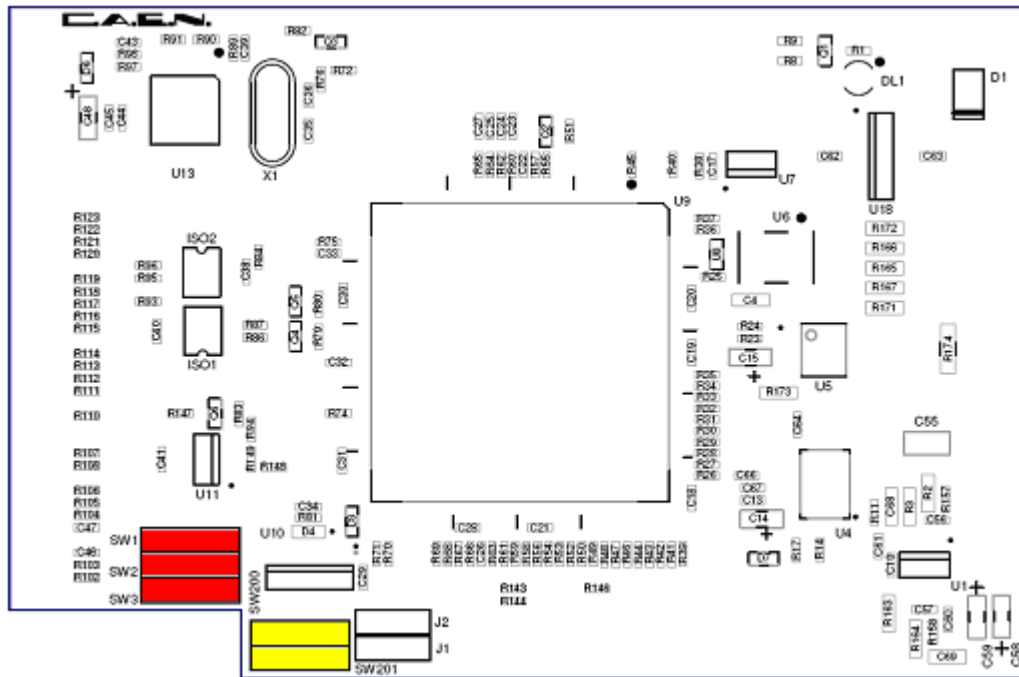

Fig. 4.3: Dip switch position

### 4.2.1 Local Bus termination

The SW[1..3] switch placed on the Microcontroller board inside the module (behind the *Remote communication control section*, see § 2.4.4), allows to terminate the Local Bus for daisy chain purposes (see § 3.4.1.2); dot NOT visible = Termination ON.

### 4.2.2 RS485 – RS232 conversion

The SW[200, 201] switch placed on the Microcontroller board inside the module, allows to adapt RS485 signals to RS232; dot visible = Adaptation ON.

## 4.3 Grounding specifications

The Mod. N14xx channels share a common floating return (FAGND), insulated from the crate ground (AGND). This feature allows on-detector grounding, thus avoiding loops which may increase noise level. FAGND and AGND may be connected, by short circuiting C21 jumper pins on the motherboard (see figure below). The protection shield must be screwed off in order to access C21 (see 4.1). Please note that older versions of the N14xx may not have C21 jumper installed; contact [info@caen.it](mailto:info@caen.it) for details.

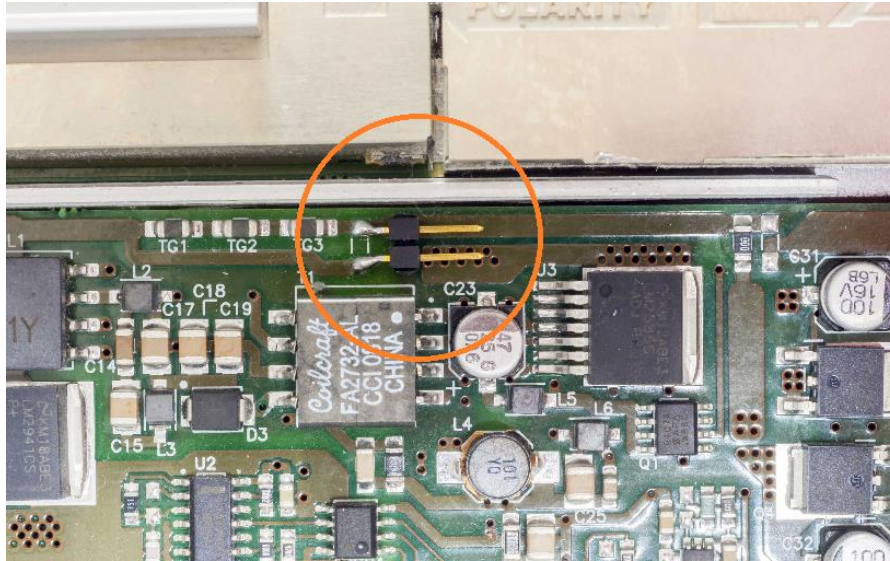

Fig. 4.4: C21 jumper location

#### 4.3.1 Safety Earth connection

The connection of return to Earth is fundamental for User safety. The connection must always be at the level of detector or power supply system.

Return connection even if not present or performed incorrectly, due to protection circuits implemented on the N14xx are bound to Earth; in this case the voltage difference between return and Earth (System), is limited to a approximately 50V. Please note that this is a status of emergency-protection, not a working one. The Connector Configurator allows to optimize the connection of the return and of AGND (Earth). The best configuration must be determined by the user upon application, the optimal connection depends on many characteristics of the related experiment.

The following diagrams show two examples of configuration, namely:

The “closed loop” Earth configuration (C21 contacts closed)

The “open loop” Earth configuration (C21 contacts open)

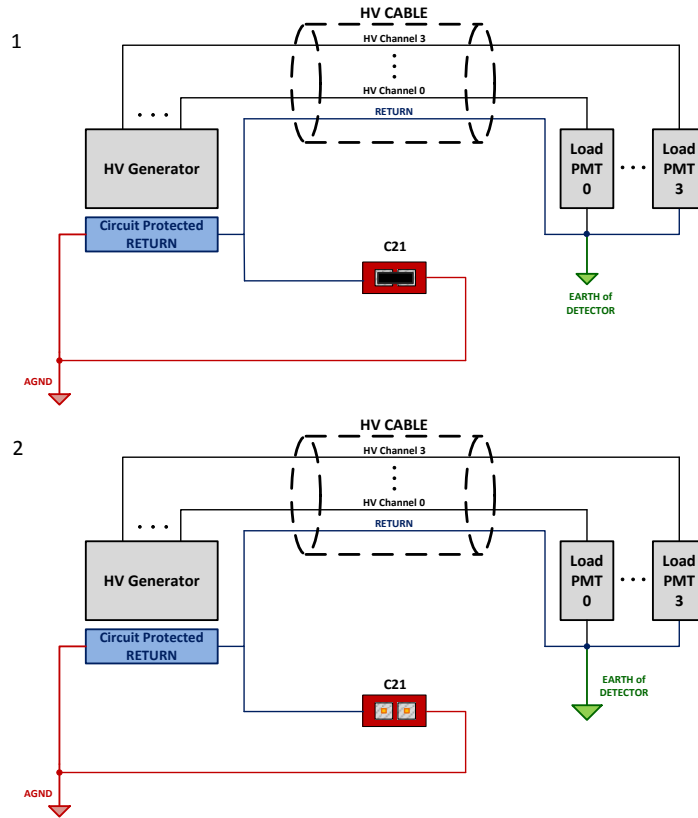

Fig. 4.5: Earth configuration connection examples